

## Kit fondello di scarico per silenziatore omologato Exhaust endcap kit for type-approved silencer



### Simbologia

Per una lettura rapida e razionale sono stati impiegati simboli che evidenziano situazioni di massima attenzione, consigli pratici o semplici informazioni.

Prestare molta attenzione al significato dei simboli, in quanto la loro funzione è quella di non dovere ripetere concetti tecnici o avvertenze di sicurezza. Sono da considerare, quindi, dei veri e propri "promemoria".

Consultare questa pagina ogni volta che sorgeranno dubbi sul loro significato.



#### Attenzione

La non osservanza delle istruzioni riportate può creare una situazione di pericolo e causare gravi lesioni personali e anche la morte.



#### Importante

Indica la possibilità di arrecare danno al veicolo e/o ai suoi componenti se le istruzioni riportate non vengono eseguite.



#### Note

Fornisce utili informazioni sull'operazione in corso.

### Riferimenti

I particolari evidenziati in grigio e riferimento numerico (Es. ①) rappresentano l'accessorio da installare e gli eventuali componenti di montaggio forniti a kit.

I particolari con riferimento alfabetico (Es. A) rappresentano i componenti originali presenti sul motoveicolo.

Tutte le indicazioni destro o sinistro si riferiscono al senso di marcia del motociclo.

### Avvertenze generali



#### Attenzione

Le operazioni riportate nelle pagine seguenti devono essere eseguite da un tecnico specializzato o da un'officina autorizzata DUCATI.



#### Attenzione

Le operazioni riportate nelle pagine seguenti se non eseguite a regola d'arte possono pregiudicare la sicurezza del pilota.



#### Note

Documentazione necessaria per eseguire il montaggio del Kit è il MANUALE OFFICINA, relativo al modello di moto in vostro possesso.



#### Note

Nel caso fosse necessaria la sostituzione di un componente del kit consultare la tavola ricambi allegata.

### Symbols

To allow quick and easy consultation, this manual uses graphic symbols to highlight situations in which maximum care is required, as well as practical advice or information.

Pay attention to the meaning of the symbols since they serve to avoid repeating technical concepts or safety warnings throughout the text. The symbols should therefore be seen as real reminders. Please refer to this page whenever in doubt as to their meaning.



#### Warning

Failure to follow these instructions might give rise to a dangerous situation and provoke severe personal injuries or even death.



#### Caution

Failure to follow these instructions might cause damages to the vehicle and/or its components.



#### Notes

Useful information on the procedure being described.

### References

Parts highlighted in grey and with a numeric reference (Example ①) are the accessory to be installed and any assembly components supplied with the kit.

Parts with an alphabetic reference (Example A) are the original components fitted on the vehicle.

Any right- or left-hand indication refers to the vehicle direction of travel.

### General notes



#### Warning

Carefully perform the operations on the following pages since they might negatively affect rider safety.



#### Warning

Carefully perform the operations on the following pages since they might negatively affect rider safety.



#### Notes

The following documents are necessary for assembling the Kit: WORKSHOP MANUAL of your bike model.



#### Notes

Should it be necessary to change any kit parts, please refer to the attached spare part table.

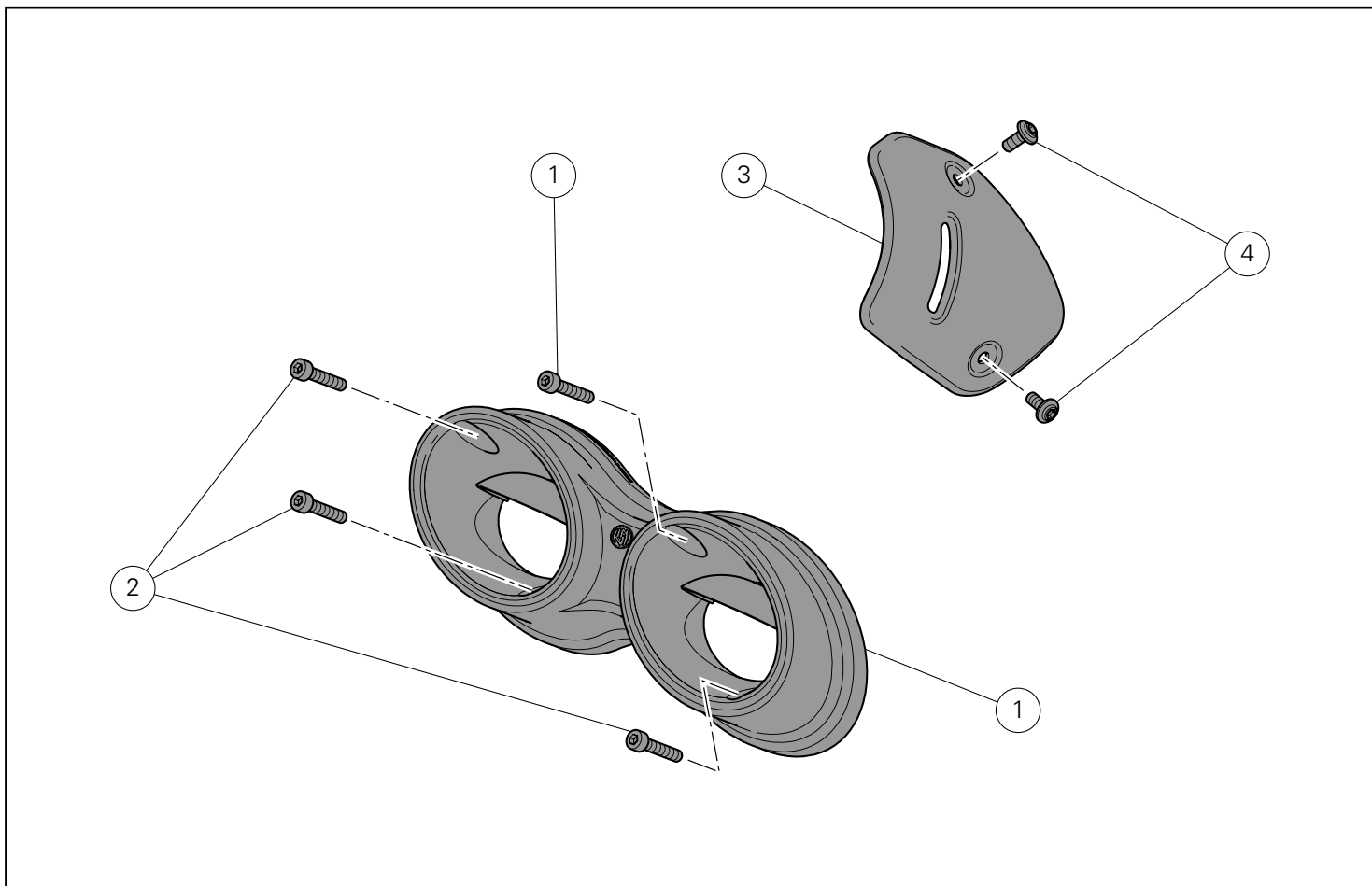

**Attenzione**

Il presente kit di scarico è per utilizzo esclusivo su pista (esempio: gare sportive su circuiti).

Dopo il montaggio del kit, il motoveicolo non può circolare su strade pubbliche.

Il proprietario si impegna ad attenersi alle leggi e regolamenti vigenti sull'utilizzo in pista e sui motoveicoli da competizione.



**Warning**

This exhaust kit is for racing use (i.e., closedcourse competition) only.

After mounting this exhaust kit, the vehicle cannot be used on public roads.

Owner is responsible for compliance with all laws concerning racing use and competition vehicles.

Pos.	Denominazione	Description
1	Fondello di scarico	Exhaust endcap
2	Vite TCEI M5X25	TCEI screw M5x25
3	Paracalore	Heat guard
4	Vite TBEI M5X12	TBEI screw M5x12

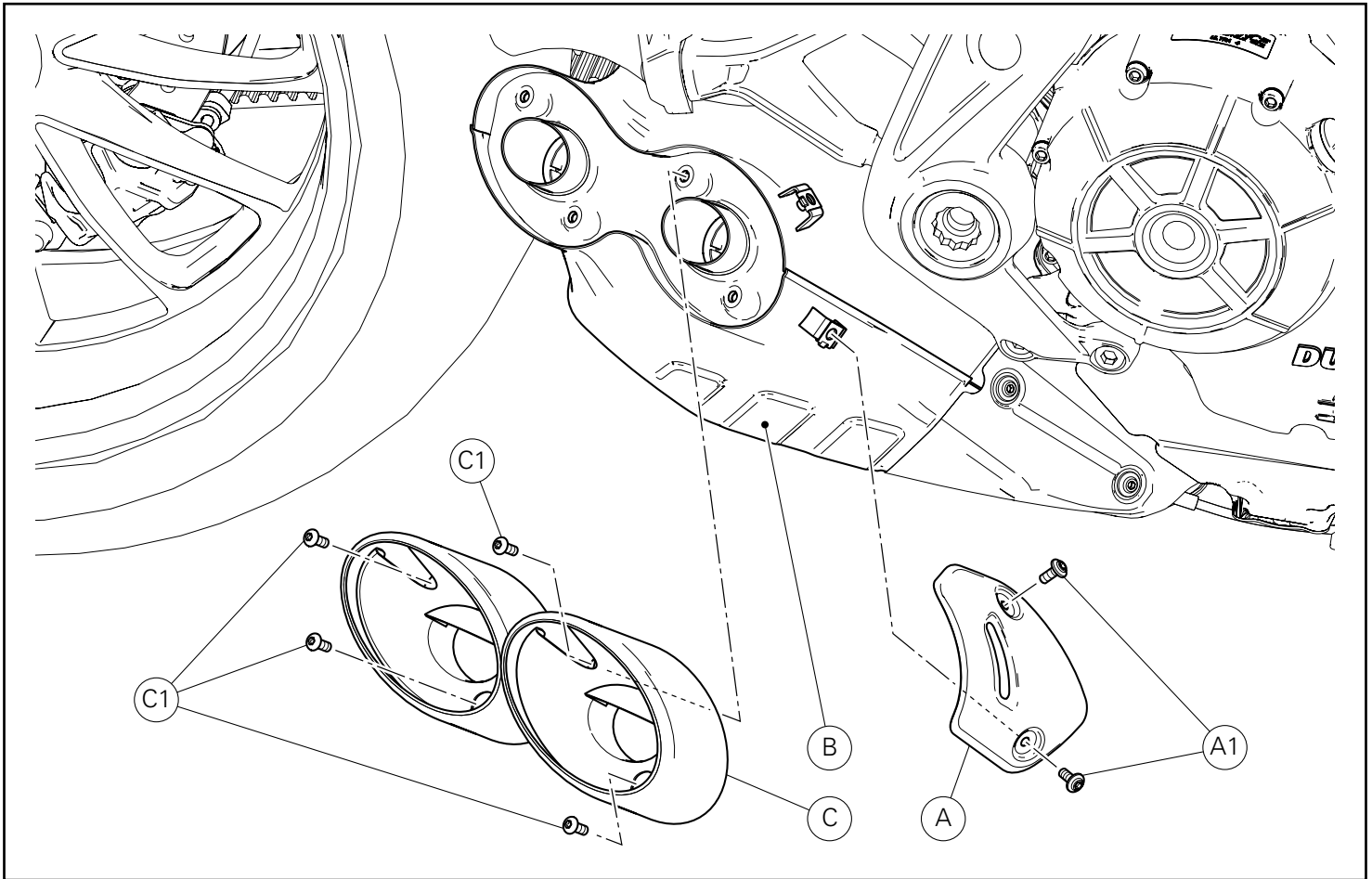

### Smontaggio componenti originali

#### Attenzione

Il motore e le parti del sistema di scarico diventano molto calde con l'uso della motocicletta, e rimangono calde ancora per lungo tempo dopo aver fatto funzionare il motore. Per manipolare queste parti usare dei guanti anticalore, o attendere che si siano ben raffreddate.

#### Attenzione

L'impianto di scarico può essere caldo, anche dopo lo spegnimento del motore; prestare molta attenzione a non toccare con nessuna parte del corpo l'impianto di scarico e a non parcheggiare il veicolo in prossimità di materiali infiammabili (compreso legno, foglie, ecc.).

#### Smontaggio paracalore

Svitare le n.2 viti (A1) e rimuovere il paracalore (A) dal silenziatore (B).

#### Smontaggio fondello silenziatore

Svitare le n.4 viti (C1) e rimuovere il fondello (C) dal silenziatore (B).

### Removing the original components

#### Warning

The engine and exhaust parts become hot when the motorcycle engine is running and will stay hot for some time after the engine has been stopped.

Wear heat-resistant gloves before handling these components or allow the engine and exhaust system to cool down before proceeding.

#### Warning

The exhaust system might be hot, even after engine is switched OFF; pay particular attention not to touch exhaust system with any body part and do not park the motorcycle next to inflammable material (wood, leaves etc.).

#### Removing the heat guard

Loosen no. 2 screws (A1) and remove heat guard (A) from silencer (B).

#### Removing the silencer endcap

Loosen no. 4 screws (C1) and remove endcap (C) from silencer (B).

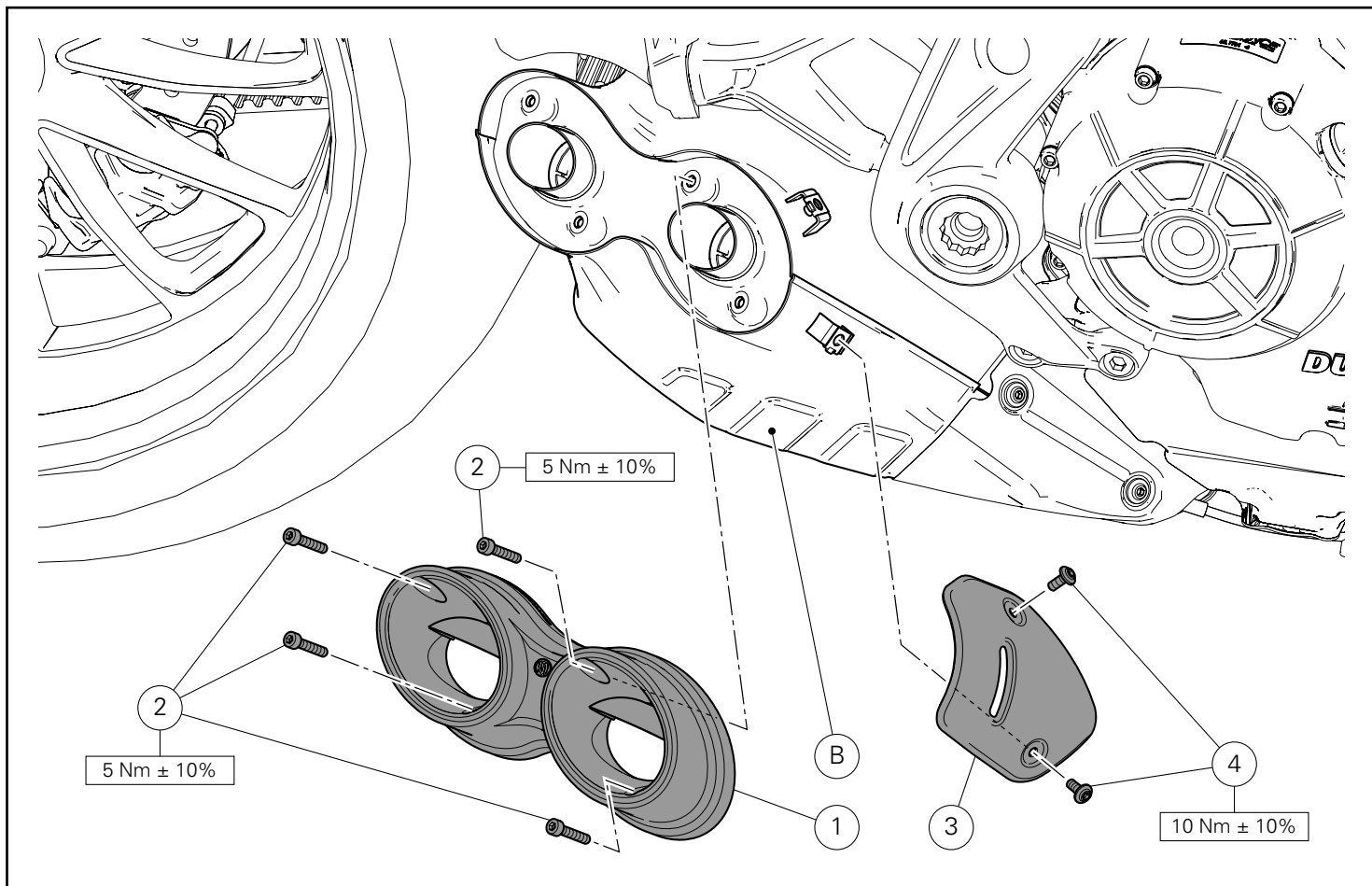

## Montaggio componenti kit

### ● Importante

Verificare, prima del montaggio, che tutti i componenti risultino puliti e in perfetto stato.  
Adottare tutte le precauzioni necessarie per evitare di danneggiare qualsiasi parte nella quale ci si trova ad operare.

### Montaggio fondello silenziatore

Posizionare il fondello (1) sul silenziatore (B) e impuntare le n.4 viti (2).  
Serrare le n.4 viti (2) alla coppia indicata.

### Montaggio paracalore

Posizionare il paracalore (3) sul silenziatore (B) e impuntare le n.2 viti (4).  
Serrare le n.2 viti (4) alla coppia indicata.

## Kit installation

### ● Caution

Check that all components are clean and in perfect condition before installation.  
Adopt any precaution necessary to avoid damages to any part of the motorcycle you are working on.

### Fitting the silencer endcap

Position endcap (1) on silencer (B) and start no. 4 screws (2).  
Tighten no.4 screws (2) to the specified torque.

### Fitting the heat guard

Position heat guard (3) on silencer (B) and start no. 2 screws (4).  
Tighten no.2 screws (4) to the specified torque.

## Kit culot d'échappement pour silencieux homologué Kit Auspuffendkappe für zugelassenen Schalldämpfer



### Symboles

Pour faciliter la consultation de ce manuel, des symboles signalent des situations exigeant le maximum d'attention, des conseils pratiques ou de simples informations. Lire attentivement la signification de ces symboles car ils renvoient à des concepts techniques ou des consignes de sécurité de la plus grande importance. Ils doivent être considérés comme de véritables « aide-mémoire ». Toujours consulter cette page en cas de doute concernant leur signification.



#### Attention

La non-observance des instructions reportées ci-dessous peut créer une situation dangereuse et provoquer de graves lésions personnelles voire la mort.



#### Important

Indique la possibilité d'endommager le véhicule et/ou ses composants si les instructions reportées ci-dessous ne sont pas suivies.



#### Remarques

Fournit des informations utiles sur l'opération en cours.

### Références

Les pièces surlignées en gris et la référence numérique (Ex. ①) représentent l'accessoire à installer et les composants de montage éventuels fournis en kit.

Les pièces avec référence alphabétique (Ex. Ⓐ) représentent les composants d'origine présents sur le motorcycle.

Toutes les indications droite ou gauche se réfèrent au sens de marche la moto.

### Avertissements généraux



#### Attention

Les opérations indiquées dans les pages suivantes, au cas où elles ne seraient pas effectuées selon les règles de l'art pourraient compromettre la sécurité du pilote.



#### Attention

Les opérations indiquées dans les pages suivantes, au cas où elles ne seraient pas effectuées selon les règles de l'art pourraient compromettre la sécurité du pilote.



#### Remarques

La documentation nécessaire pour effectuer la pose du Kit est le : MANUEL D'ATELIER, relatif au modèle de moto en votre possession.



#### Remarques

Au cas où il serait nécessaire d'effectuer le remplacement d'un composant du kit, il faudra consulter la planche relative aux pièces détachées ci-jointe.

### Symbole

Zum schnellen und übersichtlichen Lesen werden Symbole verwendet, die außerordentlich wichtige Situationen, praktische Ratschläge oder auch nur einfache Informationen hervorheben. Der Bedeutung dieser Symbole ist besondere Aufmerksamkeit zu schenken, da sich hierdurch das ständige Wiederholen von technischen Konzepten oder Sicherheitshinweisen erübrigt. Sie stellen daher regelrechte „Merker“ dar. Diese Seite ist immer dann zur Hand zu nehmen, wenn Zweifel über die Bedeutung eines Symbols bestehen sollten.



#### Achtung

Eine Nichtbeachtung der hier wiedergegebenen Anweisungen kann Gefahrensituationen schaffen und zu schweren Verletzungen und auch zum Tod führen.



#### Wichtig

Weist darauf hin, dass bei Nichteinhaltung der hier wiedergegebenen Anweisungen die Möglichkeit für Schäden am Fahrzeug und/oder seiner Komponenten besteht.



#### Hinweis

Übermittelt nützliche Informationen zum betreffenden Arbeitseingriff.

### Bezugsangaben

Die grau gekennzeichneten Bestandteile mit numerischem Bezug (Bsp. ①) geben das zu installierende Bestandteil und die eventuellen, im Kit enthaltenen Montagekomponenten wieder.

Die Bestandteile mit alphabetischem Bezug (Bsp. Ⓐ) geben die Original-Bestandteile wieder, die am Motorrad verbaut wurden.

Alle Angaben wie „rechts“ oder „links“ beziehen sich auf die Fahrtrichtung des Motorrads.

### Allgemeine Warnhinweise



#### Achtung

Werden die auf den folgenden Seiten beschriebenen Arbeitsmaßnahmen nicht fachgerecht ausgeführt, kann sich dies auf die Sicherheit des Fahrers auswirken.



#### Achtung

Werden die auf den folgenden Seiten beschriebenen Arbeitsmaßnahmen nicht fachgerecht ausgeführt, kann sich dies auf die Sicherheit des Fahrers auswirken.



#### Hinweis

Für die Montage des Kits sind folgende Unterlagen erforderlich: WERKSTATTHANDBUCH, des sich in Ihrem Besitz befindlichen Motorrads.



#### Hinweis

Sollte sich der Austausch eines Bestandteils des Kits als erforderlich erweisen, ist dazu Bezug auf die beiliegende Ersatzteilliste zu nehmen.

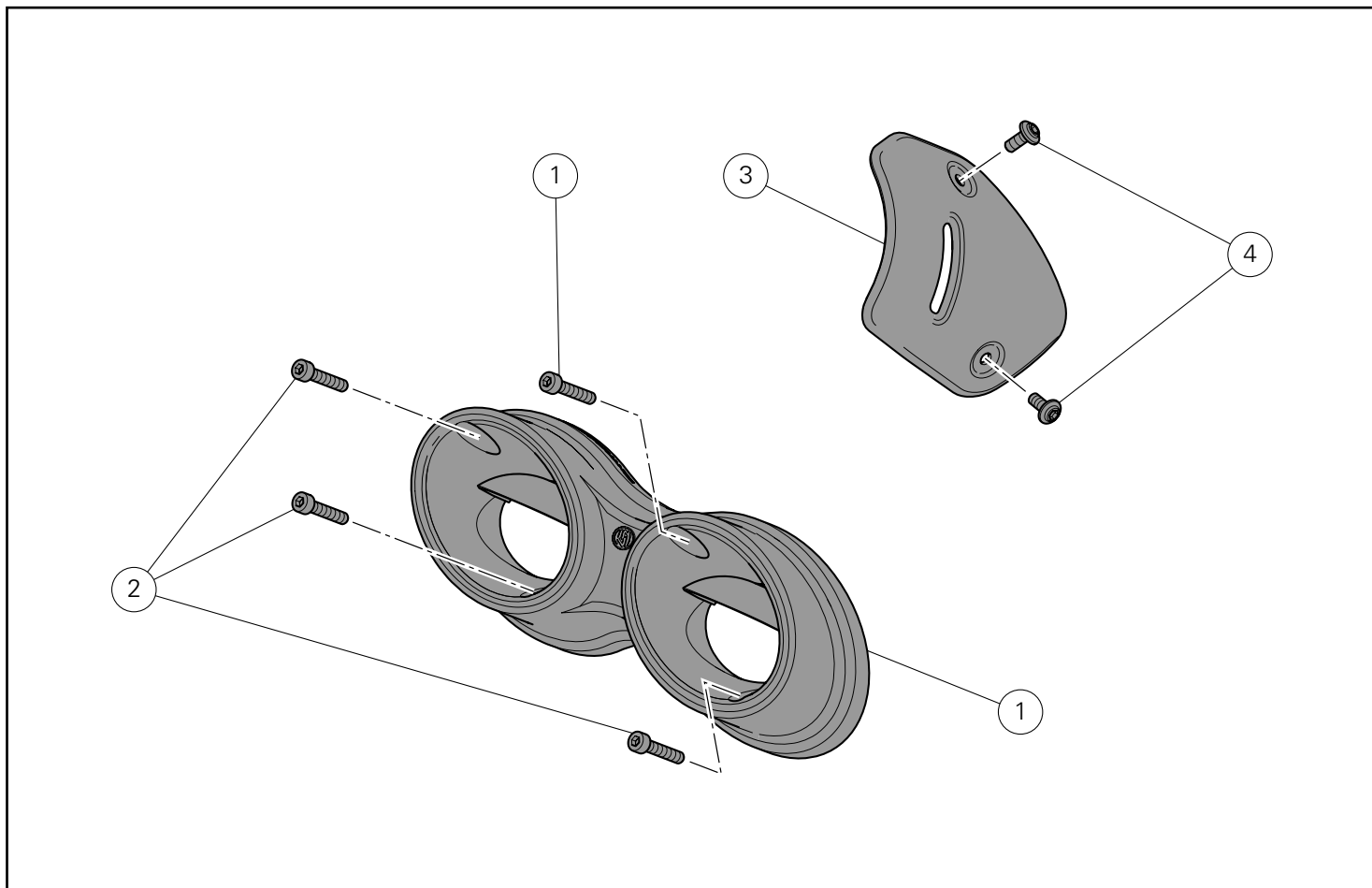

### Attention

Le présent kit d'échappement est destiné à l'usage exclusif sur piste (exemple : compétitions sportives sur circuits). Après l'installation du kit, le motorcycle ne peut pas circuler sur des voies publiques.

Le propriétaire s'engage formellement à se conformer aux lois et règlements sur l'usage des motorcycles sur piste et sur les motorcycles de compétition.



### Achtung

Vorliegendes Auspuffkit ist ausschließlich für den Einsatz auf der Rennstrecke (zum Beispiel bei Sportveranstaltungen) vorgesehen. Nach der Montage des Auspuffkits darf das Motorrad nicht mehr auf öffentlichen Straßen gefahren werden.

Der Eigentümer verpflichtet sich, die für den Einsatz auf Rennstrecken und für Rennmotorräder geltenden Gesetze und Verordnungen zu beachten.

Pos.	Designation	Bezeichnung
1	Culot d'échappement	Culot d'échappement
2	Vis TCHC M5X25	Vis TCHC M5X25
3	Pare-chaleur	Pare-chaleur
4	Vis TBHC M5x12	Vis TBHC M5x12

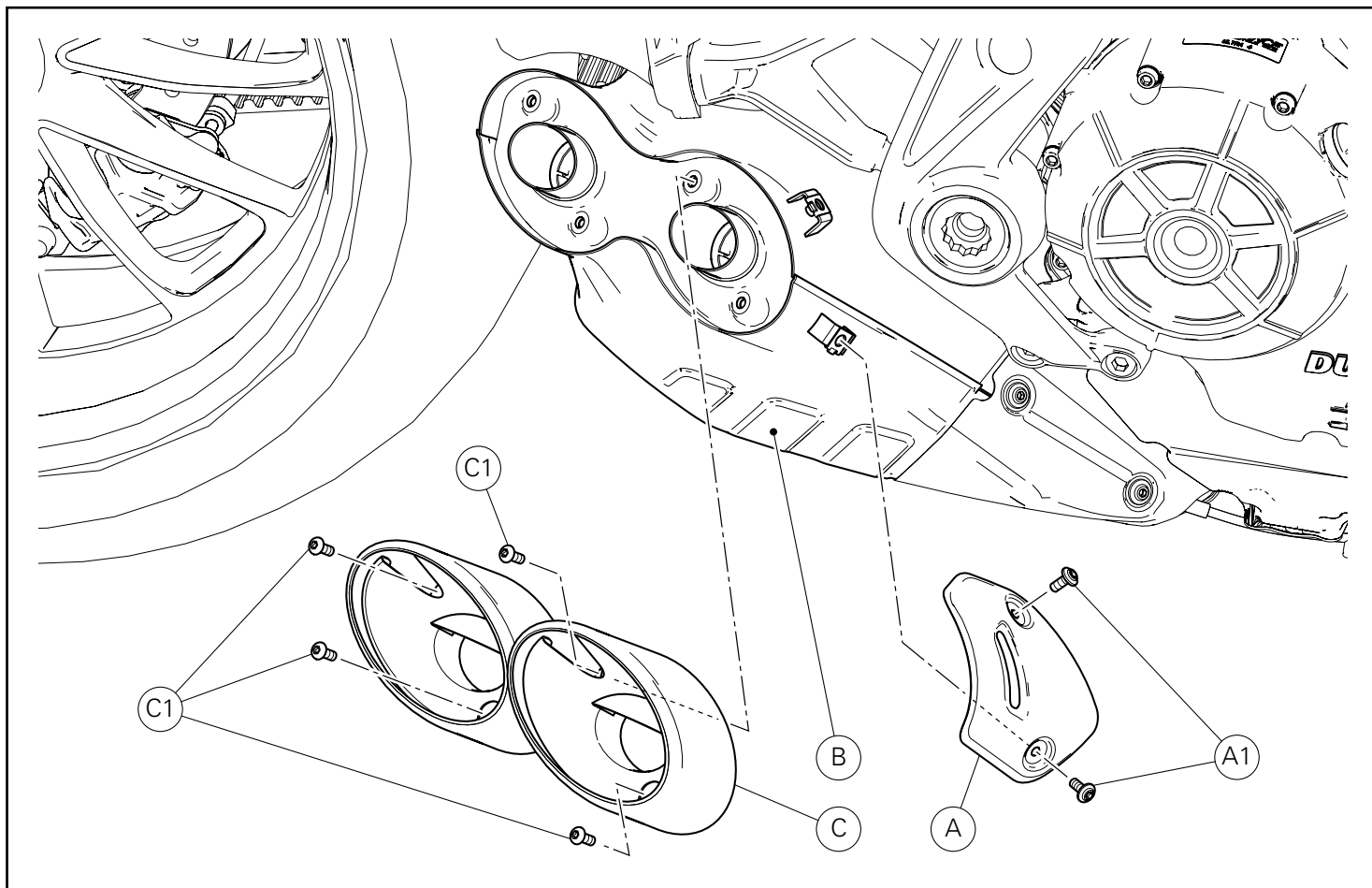

## Dépose composants d'origine

### ⚠ Attention

Le moteur et le système d'échappement atteignent des températures très élevées pendant l'utilisation de la moto et restent chauds longtemps après l'arrêt du moteur. Pour manipuler ces pièces, porter des gants isolants ou attendre qu'elles se refroidissent.

### ⚠ Attention

Le système d'échappement peut être chaud, même après avoir arrêté le moteur : prendre garde qu'aucune partie du corps ne touche le système d'échappement et veiller à ne pas garer le motorcycle à proximité de matières inflammables (y compris le bois, les feuilles, etc.).

### Dépose pare-chaueur

Desserrer les 2 vis (A1) et déposer le pare-chaueur (A) du silencieux (B).

### Dépose culot silencieux

Desserrer les 4 vis (C1) et déposer le culot (C) du silencieux (B).

## Ausbau der Original-Bestandteile

### ⚠ Achtung

Der Motor und die Auspuffanlage werden während der Fahrt sehr heiß und behalten diese Temperaturen auch nach Abstellen des Motors über lange Zeit hinweg bei. Für die Handhabung dieser Teile sind daher Wärmeschutzhandschuhe zu tragen bzw. ist so lange zu warten, bis sie abgekühlt sind.

### ⚠ Achtung

Die Auspuffanlage kann auch nach dem Ausschalten des Motors noch heiß sein, daher ist darauf zu achten, dass man mit keinem Körperteil mit der Auspuffanlage in Berührung kommt und dass das Fahrzeug nicht in der Nähe von entflammablem Material (einschließlich Holz, Blätter usw.) abgestellt wird.

### Abnahme des Hitzeschutzes

Die 2 Schrauben (A1) lösen, dann den Hitzeschutz (A) vom Schalldämpfer (B) abnehmen.

### Abnahme der Schalldämpferendkappe

Die 4 Schrauben (C1) lösen, dann die Endkappe (C) vom Schalldämpfer (B) abnehmen.

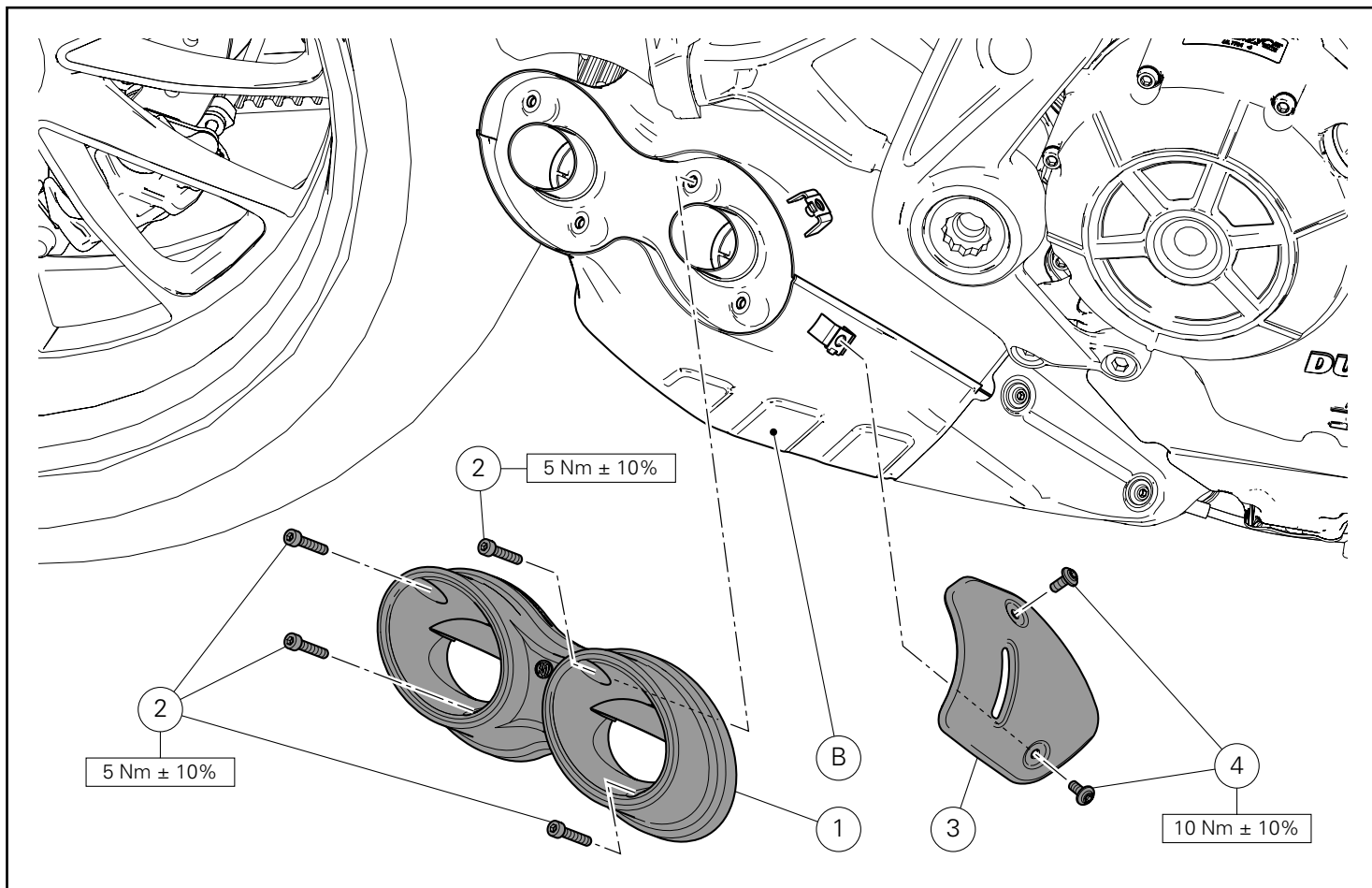

## Pose composants kit



### Important

Vérifier, avant la pose, que tous les composants sont propres et en parfait état.

Adopter toutes les précautions nécessaires pour éviter d'endommager la surface externe des composants où on opère.

### Pose culot silencieux

Positionner le culot (1) sur le silencieux (B) et présenter les 4 vis (2).

Serrer les 4 vis (2) au couple prescrit.

### Pose pare-chaleur

Positionner le pare-chaleur (3) sur le silencieux (B) et présenter les 2 vis (4).

Serrer les 2 vis (4) au couple prescrit.

## Montage der Komponenten des Kits



### Wichtig

Vor der Montage überprüfen, dass sich alle Komponenten im sauberen und perfekten Zustand befinden.

Alle erforderlichen Vorsichtsmaßnahmen treffen, um eine Beschädigung der Oberflächen der Komponenten, die vom Eingriff betroffen sind, zu vermeiden.

### Montage der Schalldämpferendkappe

Die Endkappe (1) am Schalldämpfer (B) anordnen, dann die 4 Schrauben (2) ansetzen.

Die 4 Schrauben (2) mit dem angegebenen Anzugmoment anziehen.

### Montage des Hitzeschutzes

Den Hitzeschutz (3) am Schalldämpfer (B) anordnen, dann die 2 Schrauben (4) ansetzen.

Die 2 Schrauben (4) mit dem angegebenen Anzugmoment anziehen.



## Conjunto capa de escape para silenciador homologado Exhaust endcap kit for type-approved silencer



### Símbolos

Para uma leitura rápida e racional, foram utilizados símbolos que evidenciam situações de máxima atenção, conselhos práticos ou simples informações. Preste muita atenção ao significado dos símbolos, pois a sua função é a de evitar a repetição de conceitos técnicos ou de avisos de segurança. Portanto, os símbolos devem ser considerados como verdadeiros "lembretes". Consulte esta página sempre que tiver dúvidas acerca do seu significado.



#### Atenção

O não cumprimento das instruções mostradas pode criar uma situação de perigo e causar graves lesões pessoais e até mesmo a morte.



#### Importante

Indica a possibilidade de causar danos ao veículo e/ou aos seus componentes se as instruções mostradas não forem executadas.



#### Notas

Fornecer informações úteis sobre a operação em curso.

### Referências

Os detalhes evidenciados em cinza e com referência numérica (Ex. ①) representam o acessório a ser instalado e os eventuais componentes de montagem fornecidos como kit.

Os detalhes com referência alfabética (Ex. Ⓐ) representam os componentes originais presentes na moto.

Todas as indicações direita ou esquerda, referem-se ao sentido de marcha da moto.

### Advertências gerais



#### Atenção

As operações mostradas nas páginas a seguir, se não forem executadas com boa técnica, podem prejudicar a segurança do condutor.



#### Atenção

As operações mostradas nas páginas a seguir, se não forem executadas com boa técnica, podem prejudicar a segurança do condutor.



#### Notas

Documentação necessária para executar a montagem do Conjunto: MANUAL DE OFICINA, relativo ao modelo de moto em sua posse.



#### Notas

Caso seja necessária a substituição de um componente do conjunto, consulte o quadro de peças de reposição em anexo.

### Symbols

To allow quick and easy consultation, this manual uses graphic symbols to highlight situations in which maximum care is required, as well as practical advice or information.

Pay attention to the meaning of the symbols since they serve to avoid repeating technical concepts or safety warnings throughout the text. The symbols should therefore be seen as real reminders. Please refer to this page whenever in doubt as to their meaning.



#### Warning

Failure to follow these instructions might give rise to a dangerous situation and provoke severe personal injuries or even death.



#### Caution

Failure to follow these instructions might cause damages to the vehicle and/or its components.



#### Notes

Useful information on the procedure being described.

### References

Parts highlighted in grey and with a numeric reference (Example ①) are the accessory to be installed and any assembly components supplied with the kit.

Parts with an alphabetic reference (Example Ⓐ) are the original components fitted on the vehicle.

Any right- or left-hand indication refers to the vehicle direction of travel.

### General notes



#### Warning

Carefully perform the operations on the following pages since they might negatively affect rider safety.



#### Warning

Carefully perform the operations on the following pages since they might negatively affect rider safety.



#### Notes

The following documents are necessary for assembling the Kit: WORKSHOP MANUAL of your bike model.



#### Notes

Should it be necessary to change any kit parts, please refer to the attached spare part table.

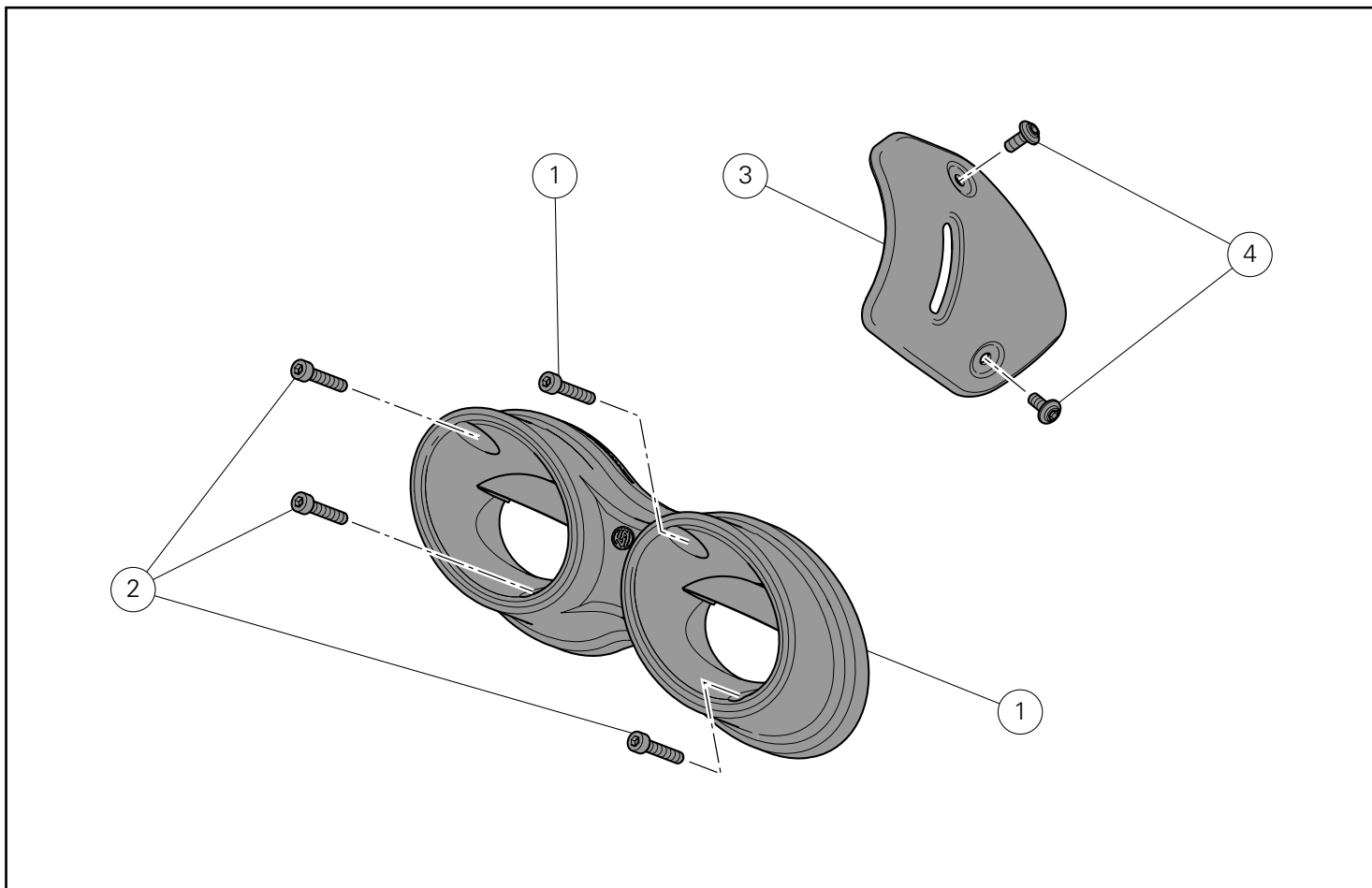

**Atenção**

Este kit de escape é para a utilização exclusiva na pista (exemplo: provas desportivas em circuitos). Após a montagem do kit, a moto não pode circular em estradas públicas. O proprietário empenha-se em respeitar as leis e regulamentos em vigor sobre a utilização na pista e sobre as motos de competição.



**Warning**

This exhaust kit is for racing use (i.e., closedcourse competition) only. After mounting this exhaust kit, the vehicle cannot be used on public roads. Owner is responsible for compliance with all laws concerning racing use and competition vehicles.

Pos.	Descrição	Description
1	Capa de escape	Exhaust endcap
2	Parafuso de cabeça cilíndrica com sextavado interno M5X25	TCEI screw M5x25
3	Proteção antic calor	Heat guard
4	Parafuso de cabeça abaulada com sextavado interno M5X12	TBEI screw M5x12

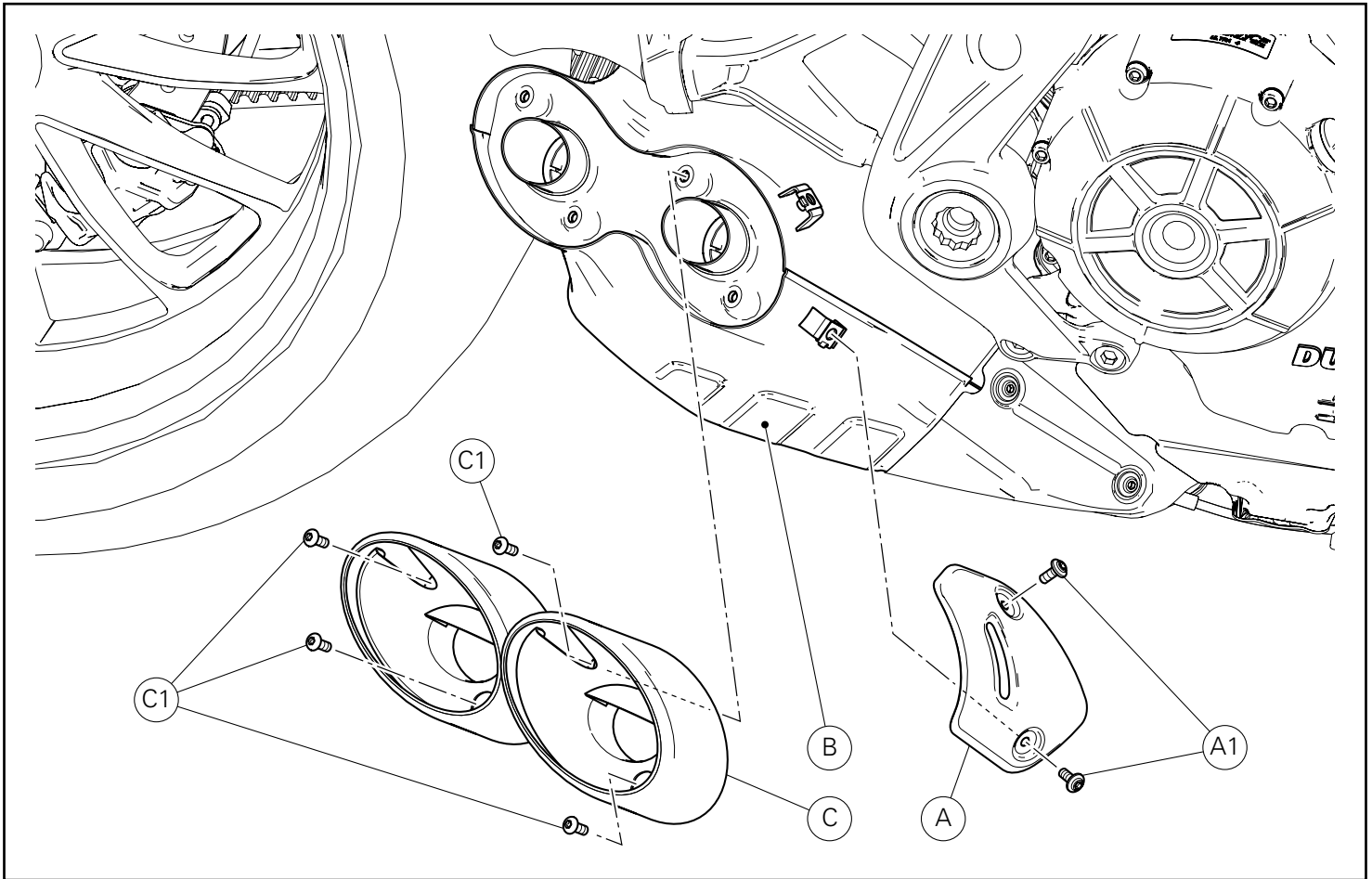

### Desmontagem dos componentes originais

#### **⚠** Atenção

O motor e as partes do sistema de escape ficam muito quentes com o uso da moto, permanecendo quentes por muito tempo mesmo depois de o motor ter sido desligado. Para manusear estas partes, use luvas para a proteção térmica ou espere que estejam bem frias.

#### **⚠** Atenção

O sistema de escape pode estar quente, mesmo depois de o motor ter sido desligado; tome muito cuidado para que nenhuma parte do corpo entre em contacto com o sistema de escape e para não estacionar o veículo perto de materiais inflamáveis (como madeira, folhas, etc.).

#### Desmontagem da proteção antic calor

Desatarraxe os 2 parafusos (A1) e remova a proteção antic calor (A) do silenciador (B).

#### Desmontagem da capa do silenciador

Desatarraxe os 4 parafusos (C1) e remova a capa (C) do silenciador (B).

### Removing the original components

#### **⚠** Warning

The engine and exhaust parts become hot when the motorcycle engine is running and will stay hot for some time after the engine has been stopped. Wear heat-resistant gloves before handling these components or allow the engine and exhaust system to cool down before proceeding.

#### **⚠** Warning

The exhaust system might be hot, even after engine is switched OFF; pay particular attention not to touch exhaust system with any body part and do not park the motorcycle next to inflammable material (wood, leaves etc.).

#### Removing the heat guard

Loosen no. 2 screws (A1) and remove heat guard (A) from silencer (B).

#### Removing the silencer endcap

Loosen no. 4 screws (C1) and remove endcap (C) from silencer (B).

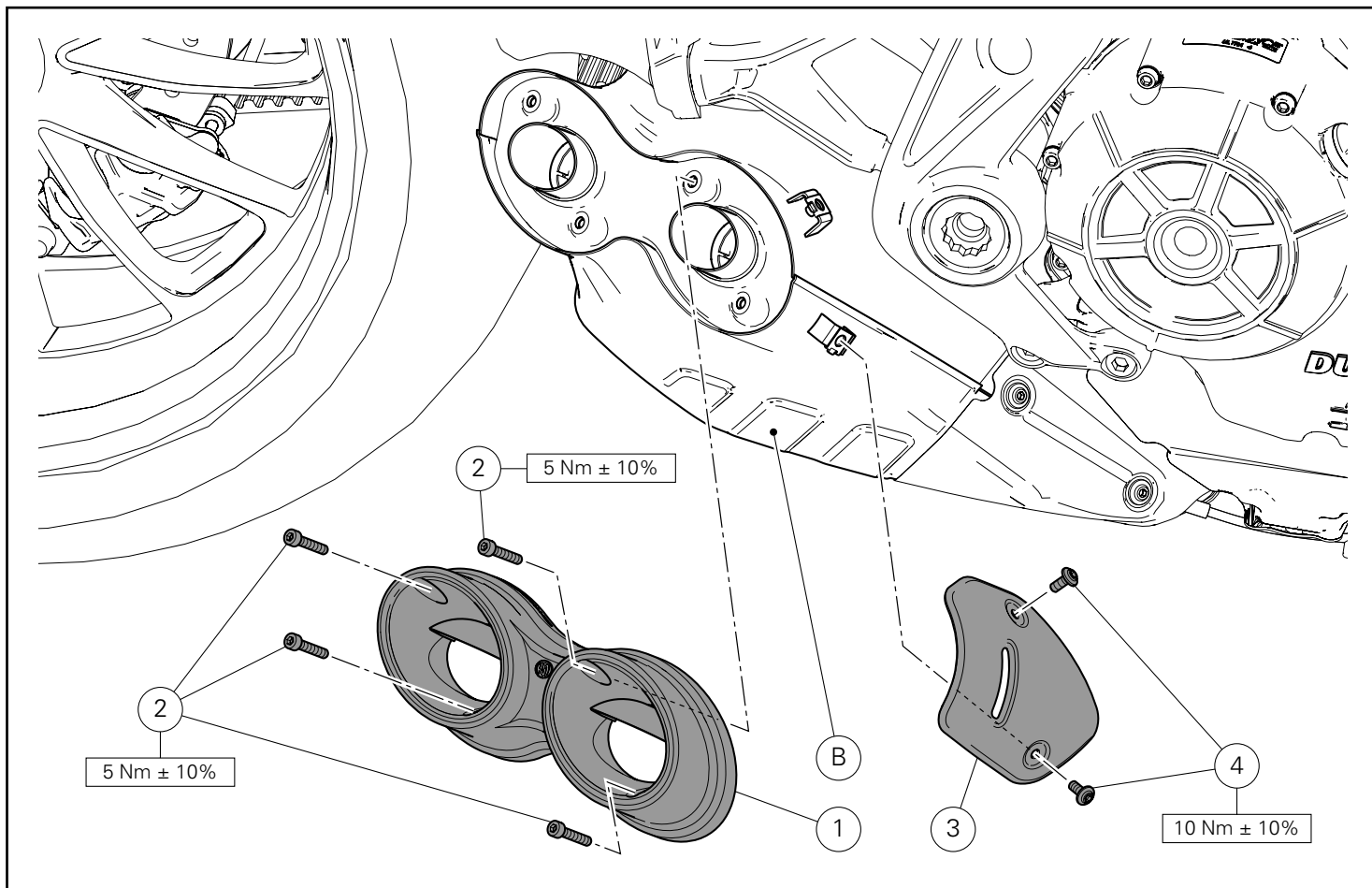

## Montagem dos componentes

### ● Importante

Verifique, antes da montagem, se todos os componentes estão limpos e em perfeito estado.

Adote todas as precauções necessárias para evitar danificar qualquer peça com a qual deve trabalhar.

### Montagem da capa do silenciador

Posicione a capa (1) no silenciador (B) e encoste os 4 parafusos (2). Aperte os 4 parafusos (2) ao binário indicado.

### Montagem da proteção antic calor

Posicione a proteção antic calor (3) no silenciador (B) e encoste os 2 parafusos (4).

Aperte os 2 parafusos (4) ao binário indicado.

## Kit installation

### ● Caution

Check that all components are clean and in perfect condition before installation.

Adopt any precaution necessary to avoid damages to any part of the motorcycle you are working on.

### Fitting the silencer endcap

Position endcap (1) on silencer (B) and start no. 4 screws (2). Tighten no.4 screws (2) to the specified torque.

### Fitting the heat guard

Position heat guard (3) on silencer (B) and start no. 2 screws (4). Tighten no.2 screws (4) to the specified torque.

## Kit tapa de escape para silenciador homologado 基準適合サイレンサー用エキゾーストエンドキャップ



### Símbolos

Para una lectura rápida y racional se han empleado símbolos que evidencian situaciones de máxima atención, consejos prácticos o simples informaciones. Prestar mucha atención al significado de los símbolos porque su función consiste en omitir la repetición de conceptos técnicos o advertencias de seguridad. Los símbolos deben considerarse como verdaderos "apuntes". Consultar esta página cada vez que se tengan dudas sobre su significado.



#### Atención

El incumplimiento de las instrucciones indicadas puede crear una situación de peligro y ocasionar graves lesiones e incluso la muerte.



#### Importante

Indica la posibilidad de provocar un daño al vehículo y/o a sus componentes si no se siguen las instrucciones indicadas.



#### Notas

Suministra útiles informaciones sobre la operación en curso.

### Referencias

Las partes resaltadas en gris y la referencia numérica (Por ej. ①) representan el accesorio que se debe instalar y los eventuales componentes de montaje suministrados en el kit.

Las partes con referencia alfabética (Por ej. Ⓐ) representan los componentes originales presentes en la motocicleta.

Todas las indicaciones derecha o izquierda se refieren al sentido de marcha de la motocicleta.

### Advertencias generales



#### Atención

Las operaciones descritas en las siguientes páginas deben realizarse correctamente para no perjudicar la seguridad del piloto.



#### Atención

Las operaciones descritas en las siguientes páginas deben realizarse correctamente para no perjudicar la seguridad del piloto.



#### Notas

La documentación necesaria para realizar el montaje del Kit es el: MANUAL DE TALLER, relativo al modelo de moto en vuestro poder.



#### Notas

Si fuera necesario sustituir un componente del kit, consultar la tabla de recambios adjunta.

### シンボル

素早くかつ合理的に読み進めることができるように、本マニュアルではいくつかのシンボルを導入し、最大限の注意を払う必要がある状況や、推奨事項、または一般情報を明確にしています。技術的概念や安全に関する警告を繰り返し記載する必要がないように機能しているので、各シンボルの意味に十分注意してください。シンボルは、実際上の“覚え書き”であると考えてください。シンボルなどの意味がわからなくなったり疑問に思う場合は、必ずこのページで調べるようにしてください。



#### 注記

この説明書に従わずに使用すると危険な状況を招き、重大なけが、あるいは死をももたらす原因となることがあります。



#### 重要

この説明書に従わずに使用すると、車体及び/ 又はその部品に損害を招く可能性があります



#### 参考

操作中の内容に関する有用な情報を掲載しています。

### 参照

灰色で表示する部品、および参照番号 (Es. ①) で表示する部品は、キットに付属する取り付け部品および組み立て部品を示します。

参照アルファベット (Es. Ⓐ) で表示する部品は、車両に付属するオリジナル部品を示します。

すべての右及び左の指示は車体の進行方向を向いたものです。

### 一般警告事項



#### 警告

以下のページに記載されている作業が規定通りに実施されないと、ライダーの安全性を脅かすおそれがあります。



#### 警告

以下のページに記載されている作業が規定通りに実施されないと、ライダーの安全性を脅かすおそれがあります。



#### 参考

キットの取り付けに必要な資料：お手持ちの車両モデルに対応するワークショップマニュアル。



#### 参考

キットの部品を交換する必要がある場合は、添付のスペアパーツ表を参照してください。

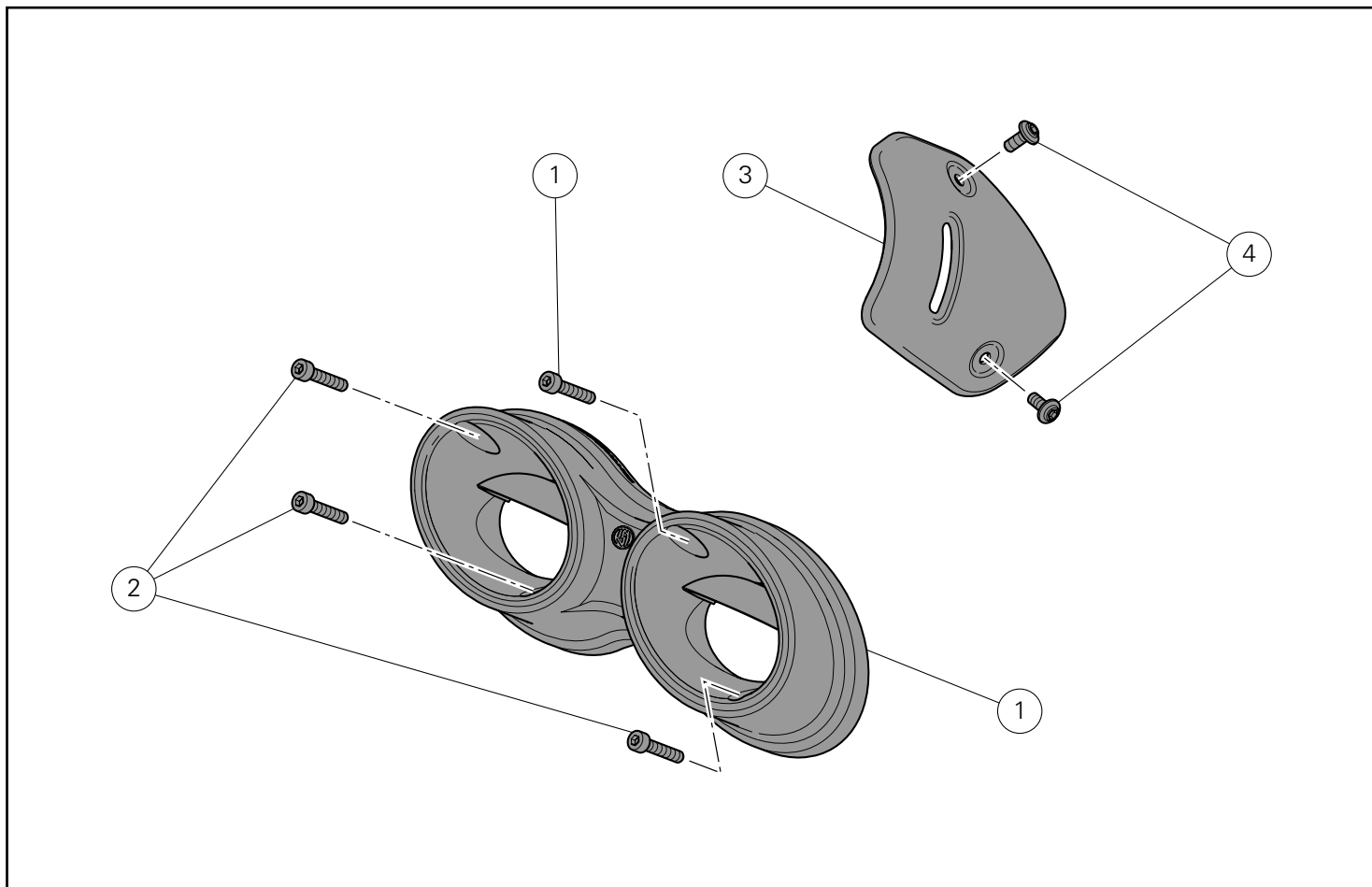

## ⚠️ Atención

El presente kit de escape debe utilizarse exclusivamente en pistas (por ejemplo, en competencias deportivas en circuitos).

Tras el montaje del kit, la motocicleta no podrá circular en carreteras públicas.

El propietario se compromete a cumplir con todas las leyes y regulaciones sobre el uso en pistas y sobre motocicletas de carreras.

## ⚠️ 注記

このエキゾーストキットはサーキット走行専用品（サーキットでのスポーツレース等）です。

本キットを取り付けた車両は一般公道を走行することはできません。

車両の所有者はサーキット走行やレース用バイクに関連する法律および規制を必ず遵守してください。

Pos.	Denominacion	説明
1	Tapa de escape	エキゾーストエンドキャップ
2	Tornillo especial TCEI M5x25	スクリュー TCEI M5X25
3	Protector calor	ヒートガード
4	Tornillo TBEI M5X12	スクリュー TBEI M5X12

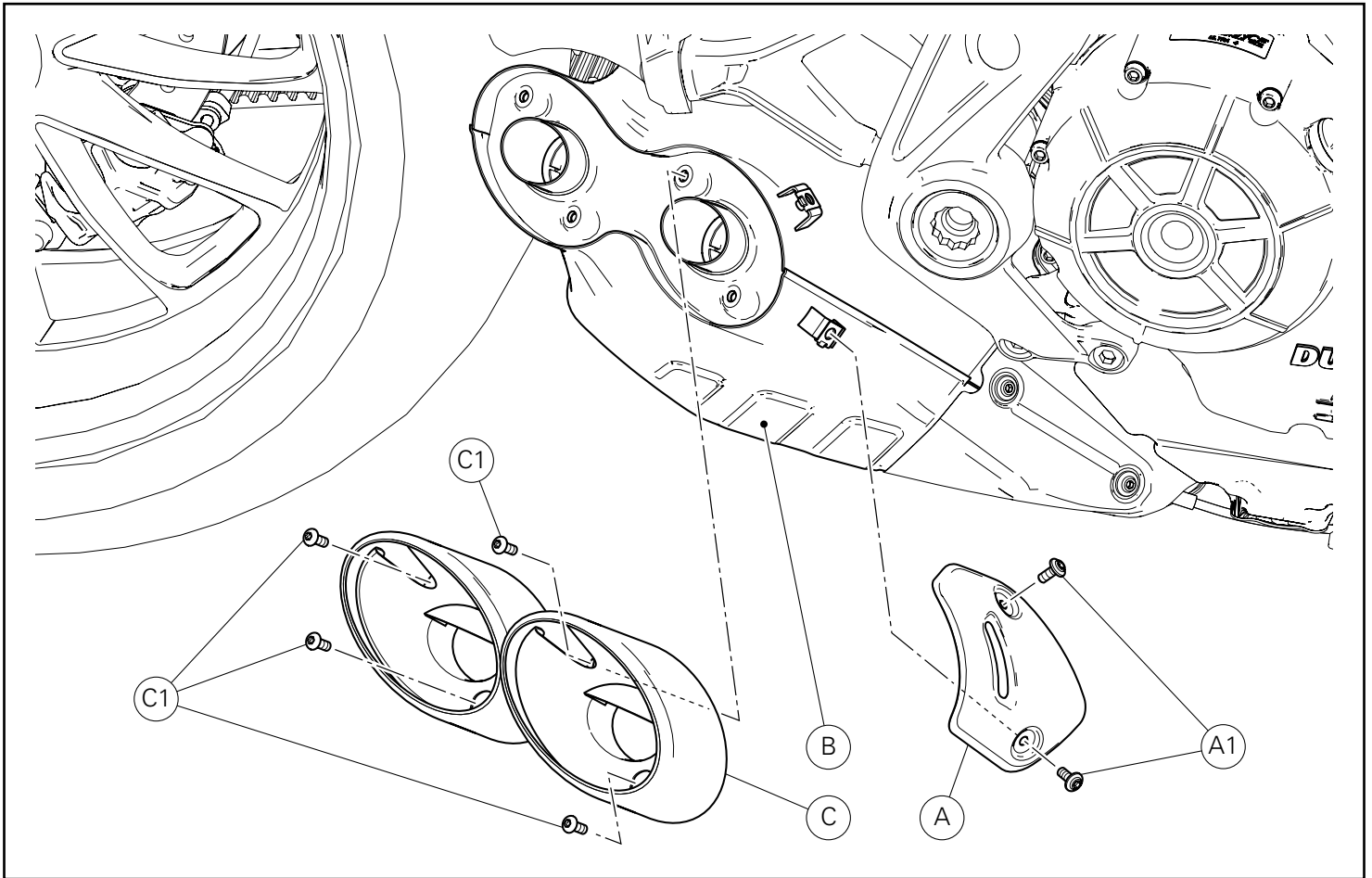

## Desmontaje componentes originales

### ⚠ Atención

El motor y el sistema de escape alcanzan altas temperaturas cuando la motocicleta está en marcha y permanecen calientes durante mucho tiempo después de apagar el motor. Para manipular estas partes, usar guantes aislantes o esperar hasta que se enfríen.

### ⚠ Atención

El sistema de escape puede estar caliente, incluso luego de apagar el motor; no tocarlo con ninguna parte del cuerpo ni aparcar la motocicleta cerca de materiales inflamables (incluidas madera, hojas, etc.).

### Desmontaje protector calor

Desatornillar los 2 tornillos (A1) y quitar el protector calor (A) del silenciador (B).

### Desmontaje tapa silenciador

Desatornillar los 4 tornillos (C1) y quitar la tapa (C) del silenciador (B).

## オリジナル部品の取り外し

### ⚠ 注記

エンジンおよびエキゾーストシステム部品は、モーターサイクルを使用することにより非常に高温になります。またエンジンを切った後も高温状態が長時間続きます。これらの部品で作業をおこなう際は、保護手袋を着用するか、部品が十分冷めるのを待ってからおこなってください。

### ⚠ 注記

エンジン停止後でもエキゾーストユニットは高温の場合があります。身体が触れないよう十分注意し、車両を木材や木の葉などの可燃物のそばに駐車しないようにしてください。

### ヒートガードの取り外し

2本のスクリュー (A1) を緩めて外し、サイレンサー (B) からヒートガード (A) を取り外します。

### サイレンサーエンドキャップの取り外し

4本のスクリュー (C1) を緩めて外し、サイレンサー (B) からエンドキャップ (C) を取り外します。

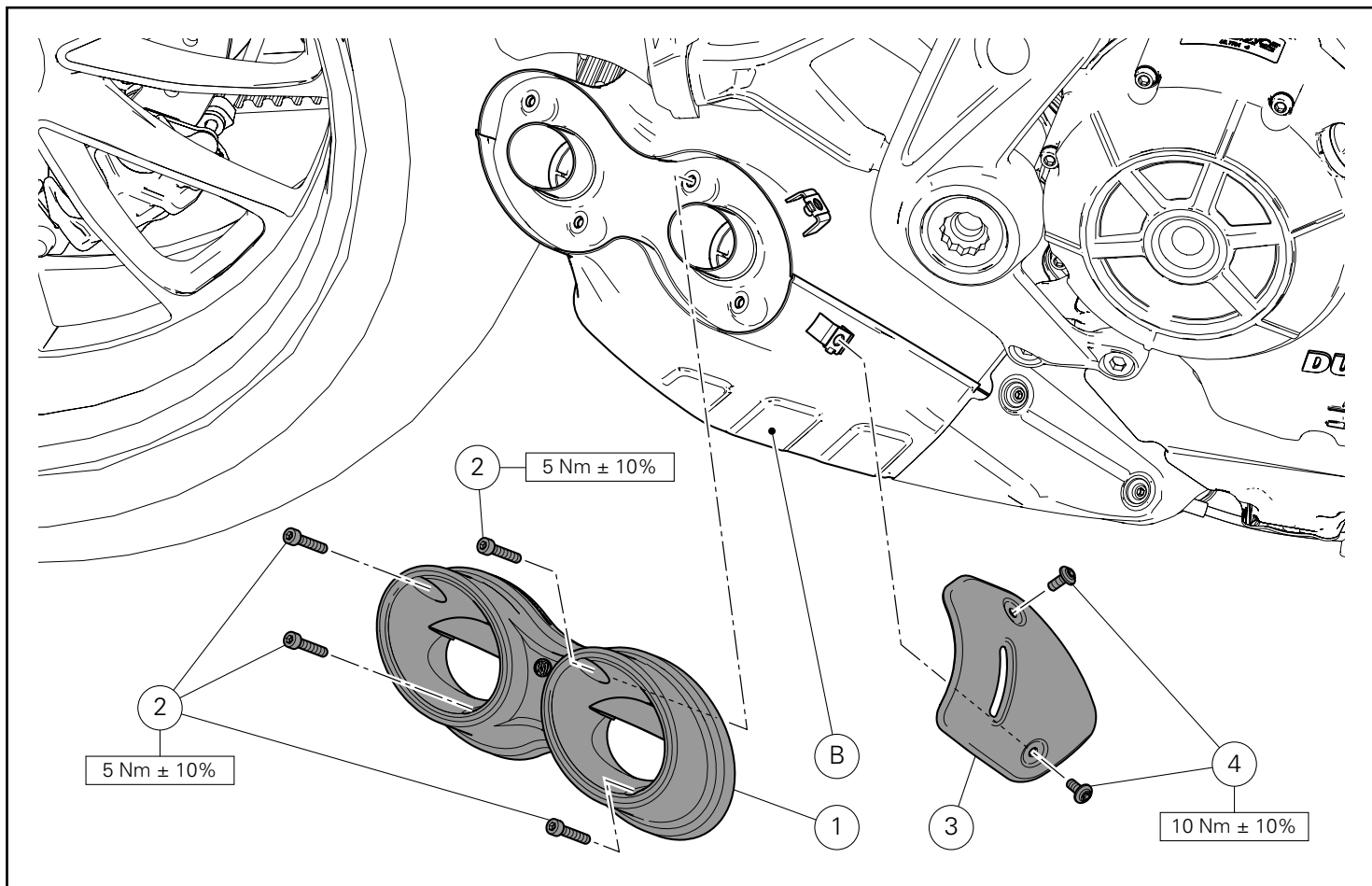

## Montaje componentes kit

### ● Importante

Controlar, antes del montaje, que todos los componentes se encuentren limpios y en perfecto estado.  
Adoptar todas las precauciones necesarias para evitar daños en la superficie exterior de los componentes donde se debe operar.

### Montaje tapa silenciador

Colocar la tapa (1) en el silenciador (B) e introducir los 4 tornillos (2).  
Ajustar los 4 tornillos (2) al par de apriete indicado.

### Montaje protector calor

Colocar el protector calor (3) en el silenciador (B) e introducir los 2 tornillos (4).  
Ajustar los 2 tornillos (4) al par de apriete indicado.

## キット部品の取り付け

### ● 重要

取り付け前にすべての部品に汚れがなく、完璧な状態であることを確認します。  
作業する部品の外側表面を傷つけないために、必要な予防措置を取ってください

### サイレンサーエンドキャップの取り付け

エンドキャップ (1) をサイレンサー (B) に配置し、4 本のスクリュー (2) を差し込みます。  
4 本のスクリュー (2) を規定のトルクで締め付けます。

### ヒートガードの取り付け

ヒートガード (3) をサイレンサー (B) に配置し、2 本のスクリュー (4) を差し込みます。  
2 本のスクリュー (4) を規定のトルクで締め付けます。





**DUCATI** PERFORMANCE accessories

## レース専用部品 ご注文書

### ご注文商品

1 P/N

商品名

2 P/N

商品名

3 P/N

商品名

4 P/N

商品名

5 P/N

商品名

### お客様ご記入欄

私は上記レース専用部品を下記車両に装着し、サーキット走行のみに利用し、一般公道には利用しません。

車台番号 ZDM

モデル名

お客様署名

ご注文日

### ドゥカティ正規ネットワーク店記入欄

お客様に上記レース専用部品を販売し、レース専用部品のご利用方法を説明いたしました。

販売店署名

販売日

年

月

日

販売店様へお願い

1. 上記ご記入の上、弊社アフターセールス部までFAXしてください。FAX:03-6692-1317
2. 取り付け車両1台に1枚でご使用ください。

Kit fondello di scarico per silenziatore omologato / Exhaust endcap kit for type-approved silencer /  
Kit culot d'échappement pour silencieux homologué / Kit Auspuffendkappe für zugelassenen Schalldämpfer /  
Conjunto capa de escape para silenciador homologado / Kit tapa de escape para silenciador homologado /  
基準適合サイレンサー用エキゾーストエキヤップ

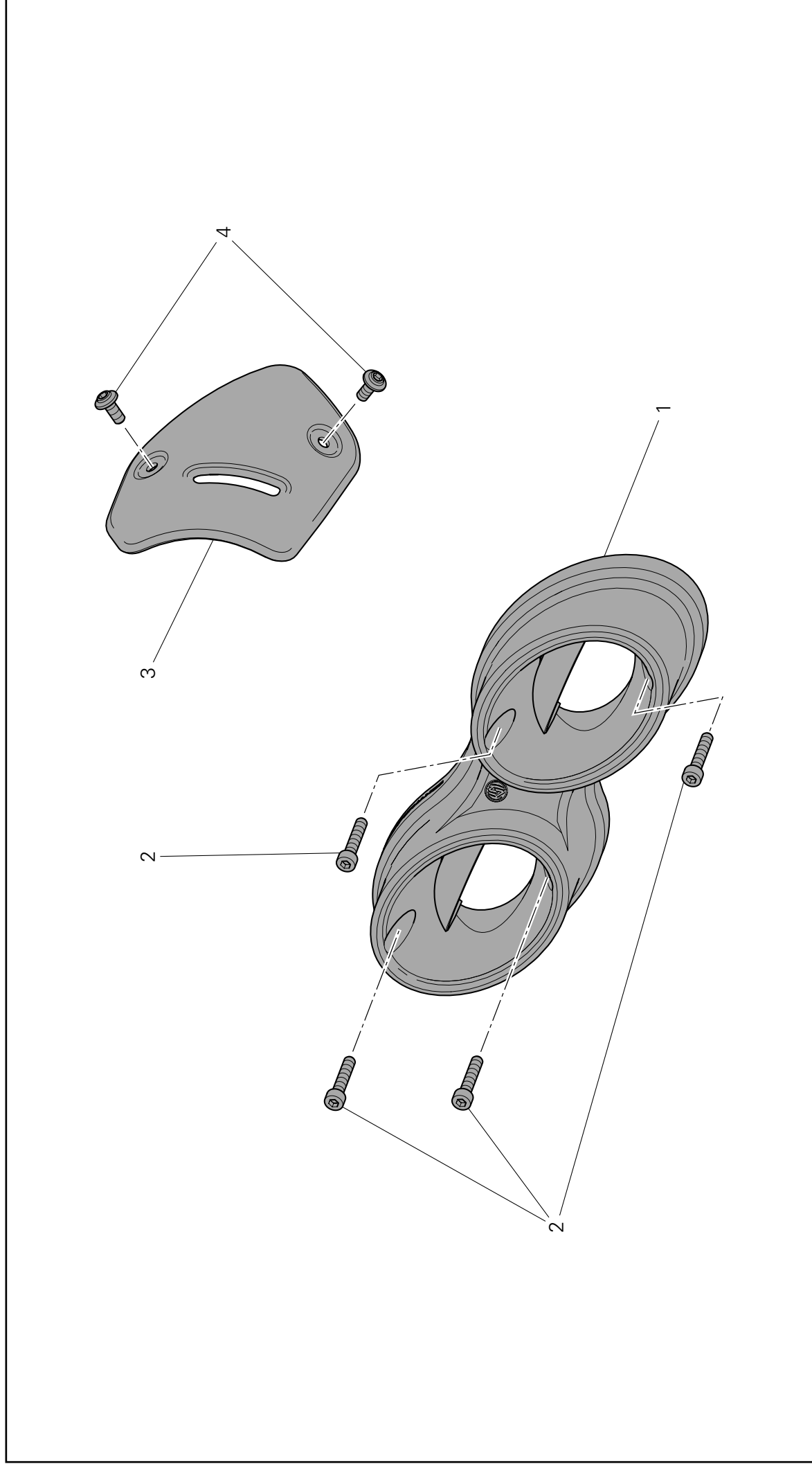

Pos.	Cod.	Denominazione	Description	Designation	Bezeichnung	Descrição	Denominacion	説明	Q.ty
1	97320991AA	Fondello di scarico	Exhaust endcap	Culot d'échappement	Culot d'échappement	Capa de escape	Tapa de escape	エキゾーストエンドキヤップ	1
2	77150458B	Vite TCEI M5X25	TCEI screw M5x25	Vis TCHC M5X25	Vis TCHC M5X25	Parafuso de cabeça cilíndrica com sextavado interno M5X25	Tornillo especial TCEI M5x25	スクリュー TCEI M5X25	4
3	96412261AA	Paracalore	Heat guard	Pare-chaleur	Pare-chaleur	Proteção antic calor	Protector calor	ヒートガード	1
4	77244173B	Vite TBEI M5X12	TBEI screw M5x12	Vis TBHC M5x12	Vis TBHC M5x12	Parafuso de cabeça abaulada com sextavado interno M5X12	Tornillo TBEI M5X12	スクリュー TBEI M5X12	2