

Kit parafango posteriore in carbonio Carbon rear mudguard kit



Simbologia

Per una lettura rapida e razionale sono stati impiegati simboli che evidenziano situazioni di massima attenzione, consigli pratici o semplici informazioni.

Prestare molta attenzione al significato dei simboli, in quanto la loro funzione è quella di non dovere ripetere concetti tecnici o avvertenze di sicurezza. Sono da considerare, quindi, dei veri e propri "promemoria".

Consultare questa pagina ogni volta che sorgeranno dubbi sul loro significato.



Attenzione

La non osservanza delle istruzioni riportate può creare una situazione di pericolo e causare gravi lesioni personali e anche la morte.



Importante

Indica la possibilità di arrecare danno al veicolo e/o ai suoi componenti se le istruzioni riportate non vengono eseguite.



Note

Fornisce utili informazioni sull'operazione in corso.

Riferimenti

I particolari evidenziati in grigio e riferimento numerico (Es. ①) rappresentano l'accessorio da installare e gli eventuali componenti di montaggio forniti a kit.

I particolari con riferimento alfabetico (Es. A) rappresentano i componenti originali presenti sul motoveicolo.

Tutte le indicazioni destro o sinistro si riferiscono al senso di marcia del motociclo.

Avvertenze generali



Attenzione

Le operazioni riportate nelle pagine seguenti devono essere eseguite da un tecnico specializzato o da un'officina autorizzata DUCATI.



Attenzione

Le operazioni riportate nelle pagine seguenti se non eseguite a regola d'arte possono pregiudicare la sicurezza del pilota.



Note

Documentazione necessaria per eseguire il montaggio del Kit è il MANUALE OFFICINA, relativo al modello di moto in vostro possesso.



Note

Nel caso fosse necessaria la sostituzione di un componente del kit consultare la tavola ricambi allegata.

Symbols

To allow quick and easy consultation, this manual uses graphic symbols to highlight situations in which maximum care is required, as well as practical advice or information.

Pay attention to the meaning of the symbols since they serve to avoid repeating technical concepts or safety warnings throughout the text. The symbols should therefore be seen as real reminders. Please refer to this page whenever in doubt as to their meaning.



Warning

Failure to follow these instructions might give raise to a dangerous situation and provoke severe personal injuries or even death.



Caution

Failure to follow these instructions might cause damages to the vehicle and/or its components.



Notes

Useful information on the procedure being described.

References

Parts highlighted in grey and with a numeric reference (Example ①) are the accessory to be installed and any assembly components supplied with the kit.

Parts with an alphabetic reference (Example A) are the original components fitted on the vehicle.

Any right- or left-hand indication refers to the vehicle direction of travel.

General notes



Warning

Carefully perform the operations on the following pages since they might negatively affect rider safety.



Warning

Carefully perform the operations on the following pages since they might negatively affect rider safety.



Notes

The following documents are necessary for assembling the Kit: WORKSHOP MANUAL of your bike model.



Notes

Should it be necessary to change any kit parts, please refer to the attached spare part table.

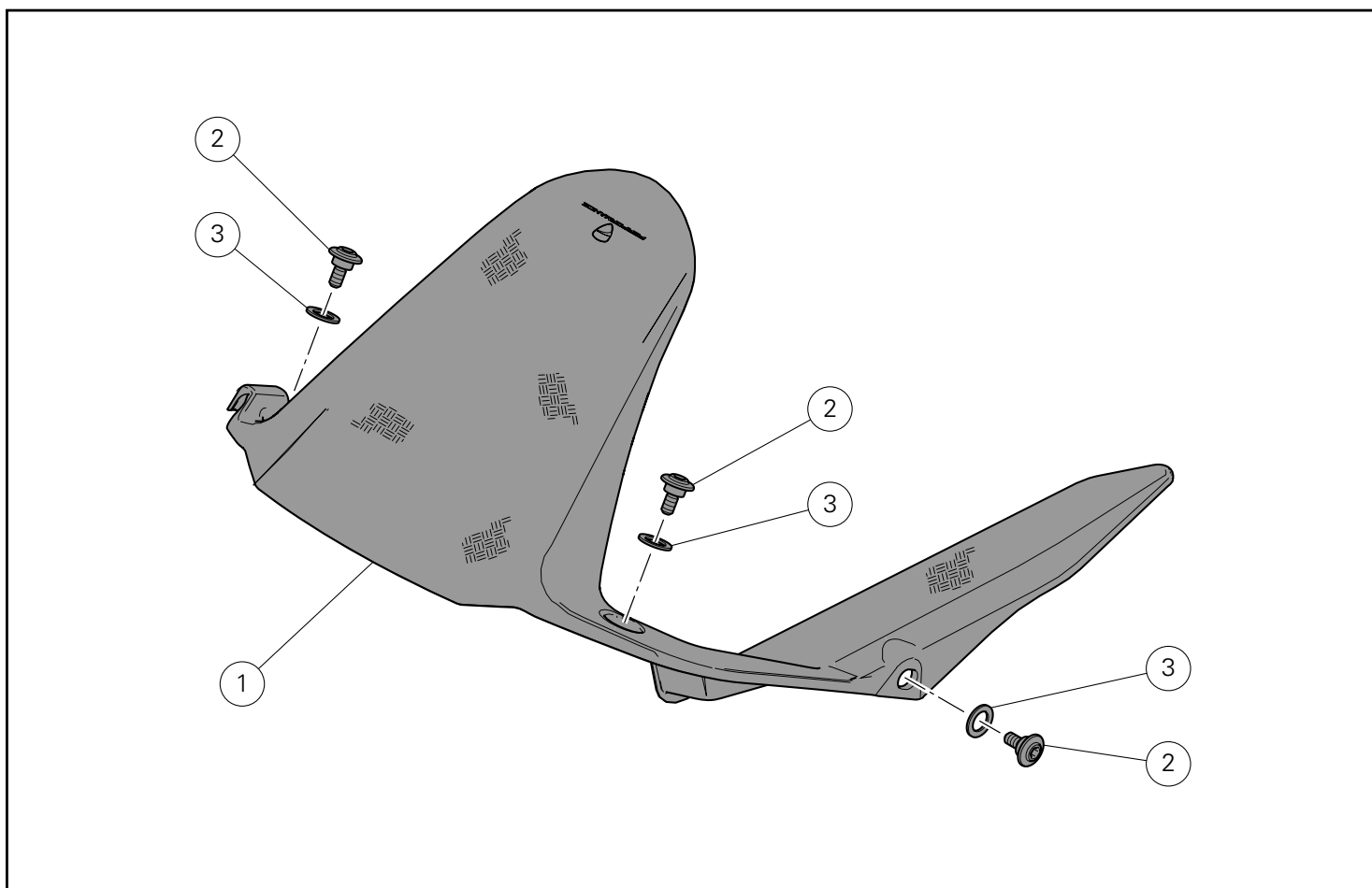

| Pos. | Denominazione | Description |
|------|----------------------------------|-------------------------|
| 1 | Parafango posteriore in carbonio | Carbon rear mudguard |
| 2 | Vite speciale TCEI M5X9 | Special TCEI screw M5x9 |
| 3 | Rosetta in nylon | Nylon washer |

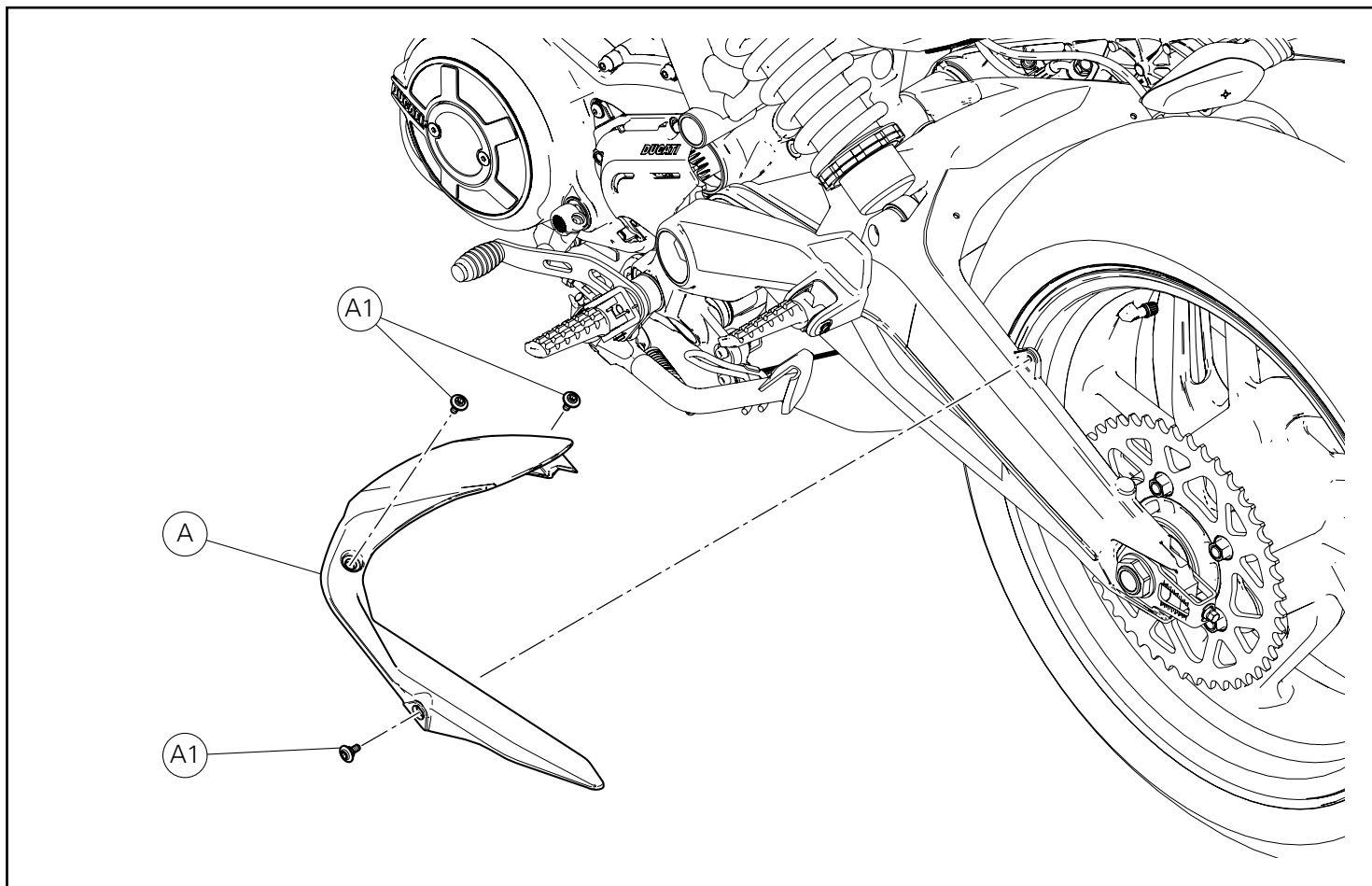

Smontaggio componenti originali

Removing the original components

Smontaggio parafango posteriore

Removing the rear mudguard

Svitare le n.3 viti (A1) e rimuovere il parafango posteriore (A).

Loosen no. 3 screws (A1) and remove rear mudguard (A).

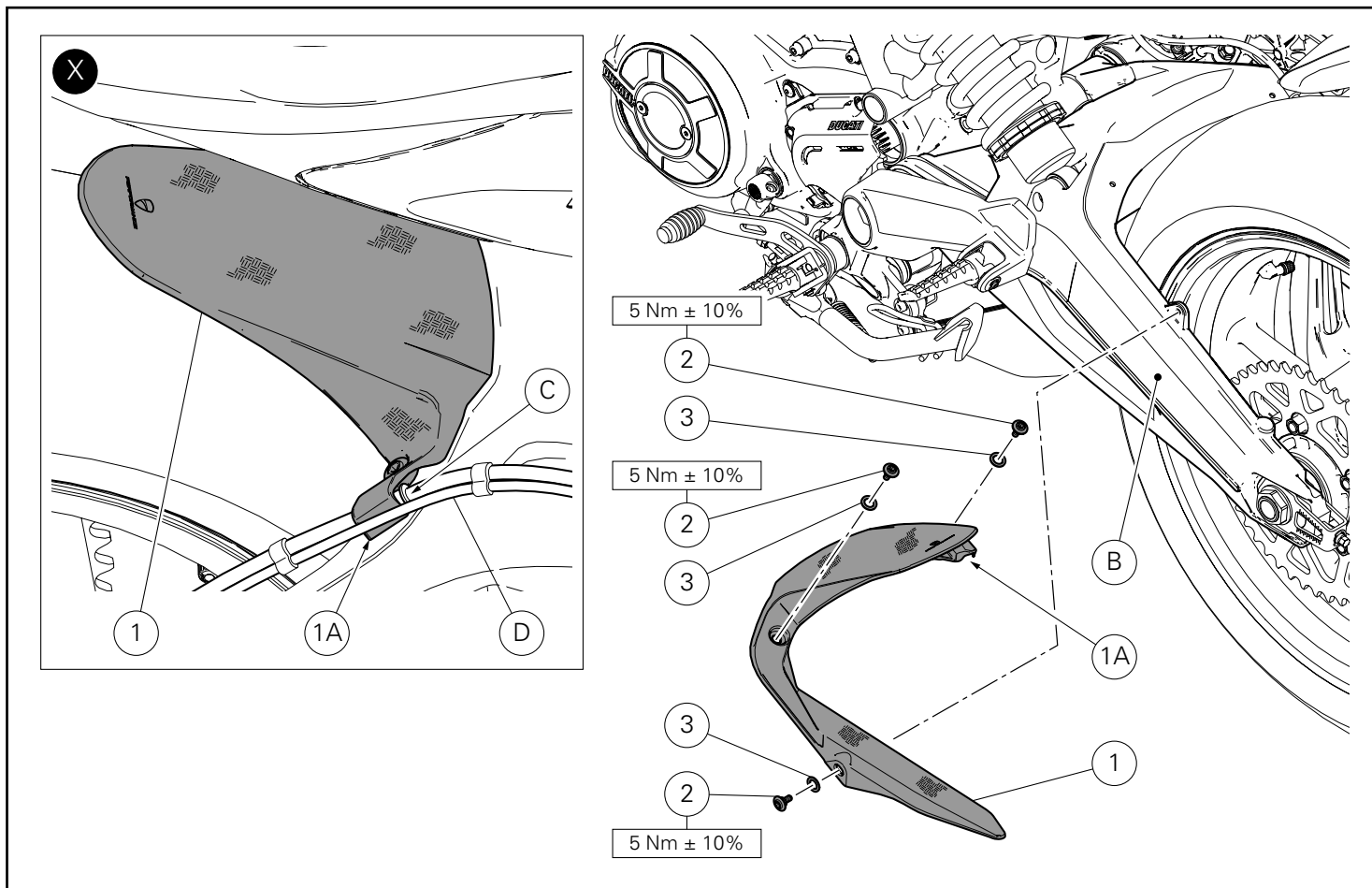

Montaggio componenti kit

● Importante

Verificare, prima del montaggio, che tutti i componenti risultino puliti e in perfetto stato.
Adottare tutte le precauzioni necessarie per evitare di danneggiare qualsiasi parte nella quale ci si trova ad operare.

⚠ Attenzione

Durante il montaggio di componenti in carbonio porre particolare attenzione al serraggio delle viti di fissaggio.
Serrare gli elementi di fissaggio senza forzare eccessivamente per evitare che il carbonio si danneggi.

Montaggio parafrangente posteriore

Introdurre le n.3 rosette in nylon (3) sul filetto delle n.3 viti (2).
Applicare LOCTITE 243 sul filetto delle n.3 viti (1).
Posizionare il parafrangente posteriore in carbonio (1) sul forcellone (B) e impuntare le n.3 viti (2).
Assicurarsi che il gommino passatubo (C) sia posizionato al di sotto dell'apposito alloggiamento (1A) presente sul parafrangente posteriore in carbonio (1).

● Importante

Il cavo sensore velocità posteriore (D) deve essere posizionato all'esterno del parafrangente in carbonio (1), come mostrato in figura (X).

Serrare le n.3 viti (2) alla coppia indicata.

Kit installation

● Caution

Check that all components are clean and in perfect condition before installation.
Adopt any precaution necessary to avoid damages to any part of the motorcycle you are working on.

⚠ Warning

When fitting carbon parts, take special care when tightening fastening screws.
Tighten fasteners without forcing too much to prevent carbon parts from being damaged.

Rear mudguard assembly

Insert no. 3 original nylon washers (3) on the thread of no. 3 screws (2).
Apply LOCTITE 243 on the thread of no.3 screws (1).
Position the rear carbon mudguard (1) on the swinging arm (B) and start no.3 screws (2).
Make sure that the hose grommet (C) is positioned under its housing (1A) on the rear carbon mudguard (1).

● Caution

The rear speed sensor cable (D) must be positioned on the outside of the carbon mudguard (1) as shown in the figure (X).

Tighten no.3 screws (2) to the specified torque.

Kit garde-boue arrière en carbone Kit hinterer Kotflügel aus Kohlefaser



Symboles

Pour faciliter la consultation de ce manuel, des symboles signalent des situations exigeant le maximum d'attention, des conseils pratiques ou de simples informations. Lire attentivement la signification de ces symboles car ils renvoient à des concepts techniques ou des consignes de sécurité de la plus grande importance. Ils doivent être considérés comme de véritables « aide-mémoire ». Toujours consulter cette page en cas de doute concernant leur signification.



Attention

La non-observance des instructions reportées ci-dessous peut créer une situation dangereuse et provoquer de graves lésions personnelles voire la mort.



Important

Indique la possibilité d'endommager le véhicule et/ou ses composants si les instructions reportées ci-dessous ne sont pas suivies.



Remarques

Fournit des informations utiles sur l'opération en cours.

Références

Les pièces surlignées en gris et la référence numérique (Ex. ①) représentent l'accessoire à installer et les composants de montage éventuels fournis en kit.

Les pièces avec référence alphabétique (Ex. Ⓐ) représentent les composants d'origine présents sur le motorcycle.

Toutes les indications droite ou gauche se réfèrent au sens de marche la moto.

Avertissements généraux



Attention

Les opérations indiquées dans les pages suivantes, au cas où elles ne seraient pas effectuées selon les règles de l'art pourraient compromettre la sécurité du pilote.



Attention

Les opérations indiquées dans les pages suivantes, au cas où elles ne seraient pas effectuées selon les règles de l'art pourraient compromettre la sécurité du pilote.



Remarques

La documentation nécessaire pour effectuer la pose du Kit est le : MANUEL D'ATELIER, relatif au modèle de moto en votre possession.



Remarques

Au cas où il serait nécessaire d'effectuer le remplacement d'un composant du kit, il faudra consulter la planche relative aux pièces détachées ci-jointe.

Symbole

Zum schnellen und übersichtlichen Lesen werden Symbole verwendet, die außerordentlich wichtige Situationen, praktische Ratschläge oder auch nur einfache Informationen hervorheben. Der Bedeutung dieser Symbole ist besondere Aufmerksamkeit zu schenken, da sich hierdurch das ständige Wiederholen von technischen Konzepten oder Sicherheitshinweisen erübrigt. Sie stellen daher regelrechte „Merker“ dar. Diese Seite ist immer dann zur Hand zu nehmen, wenn Zweifel über die Bedeutung eines Symbols bestehen sollten.



Achtung

Eine Nichtbeachtung der hier wiedergegebenen Anweisungen kann Gefahrensituationen schaffen und zu schweren Verletzungen und auch zum Tod führen.



Wichtig

Weist darauf hin, dass bei Nichteinhaltung der hier wiedergegebenen Anweisungen die Möglichkeit für Schäden am Fahrzeug und/oder seiner Komponenten besteht.



Hinweis

Übermittelt nützliche Informationen zum betreffenden Arbeitseingriff.

Bezugsangaben

Die grau gekennzeichneten Bestandteile mit numerischem Bezug (Bsp. ①) geben das zu installierende Bestandteil und die eventuellen, im Kit enthaltenen Montagekomponenten wieder.

Die Bestandteile mit alphabetischem Bezug (Bsp. Ⓐ) geben die Original-Bestandteile wieder, die am Motorrad verbaut wurden.

Alle Angaben wie „rechts“ oder „links“ beziehen sich auf die Fahrtrichtung des Motorrads.

Allgemeine Warnhinweise



Achtung

Werden die auf den folgenden Seiten beschriebenen Arbeitsmaßnahmen nicht fachgerecht ausgeführt, kann sich dies auf die Sicherheit des Fahrers auswirken.



Achtung

Werden die auf den folgenden Seiten beschriebenen Arbeitsmaßnahmen nicht fachgerecht ausgeführt, kann sich dies auf die Sicherheit des Fahrers auswirken.



Hinweis

Für die Montage des Kits sind folgende Unterlagen erforderlich: WERKSTATTHANDBUCH, des sich in Ihrem Besitz befindlichen Motorrads.



Hinweis

Sollte sich der Austausch eines Bestandteils des Kits als erforderlich erweisen, ist dazu Bezug auf die beiliegende Ersatzteilliste zu nehmen.

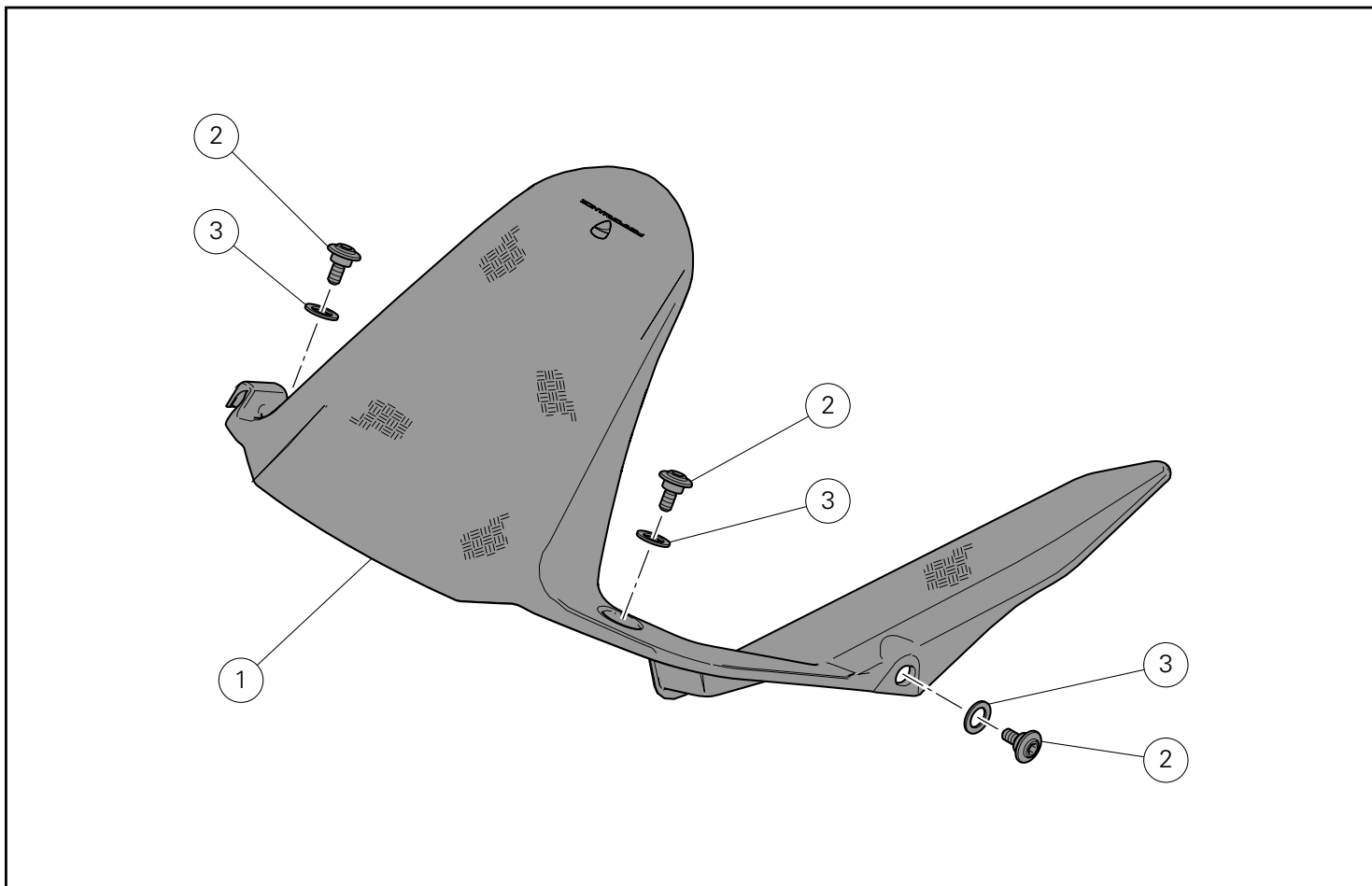

| Pos. | Designation | Bezeichnung |
|------|-------------------------------|-------------------------------------|
| 1 | Garde-boue arrière en carbone | Hinterer Kotflügel aus Kohlefaser |
| 2 | Vis spéciale TCHC M5x9 | Spezial-Innensechskantschraube M5x9 |
| 3 | Rondelle en nylon | Unterlegscheibe aus Nylon |

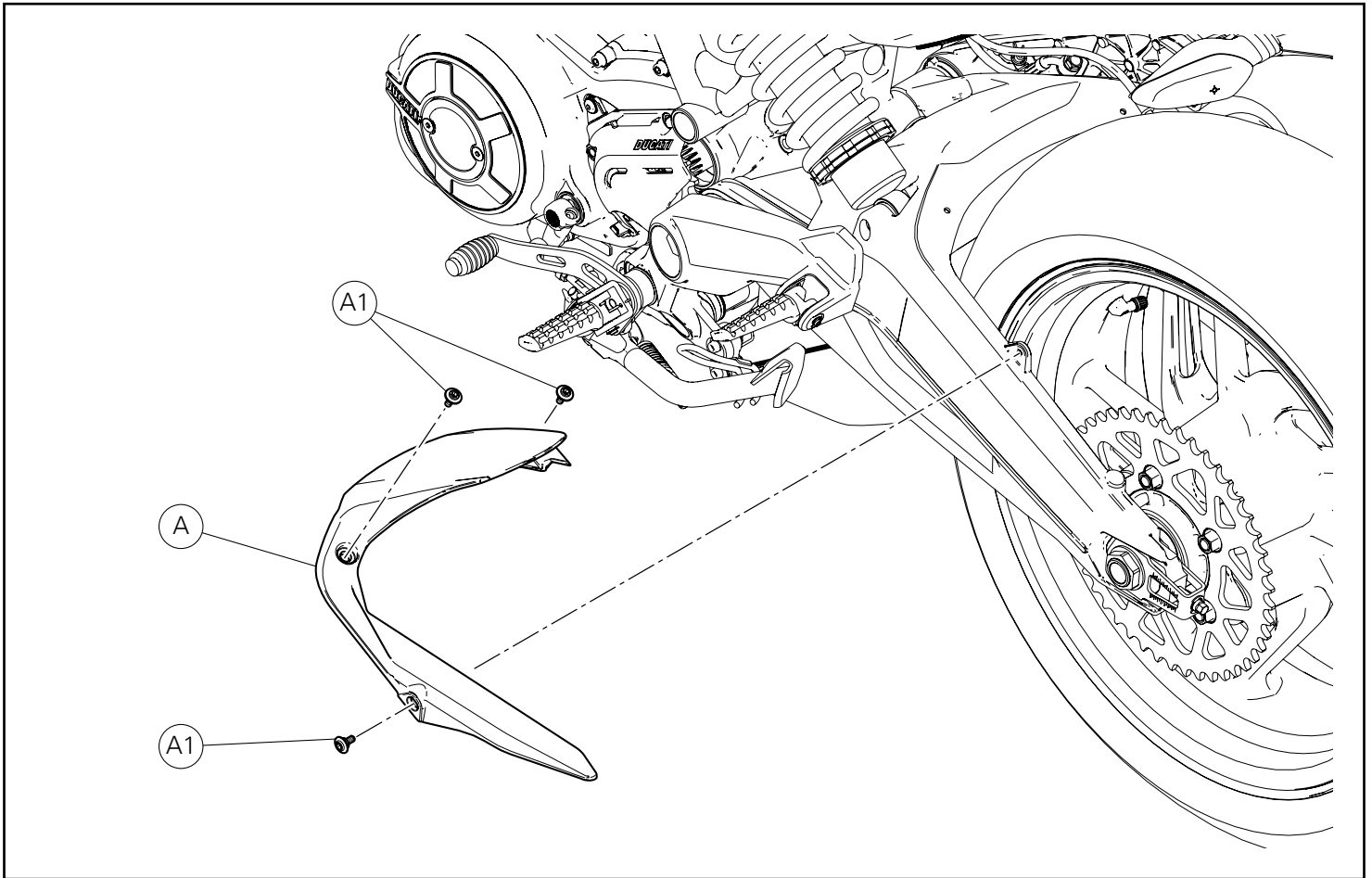

Dépose composants d'origine

Dépose du garde-boue arrière

Desserrer les 3 vis (A1) et déposer le garde-boue arrière (A).

Ausbau der Original-Bestandteile

Abnahme des Schalldämpfers

Die 3 Schrauben (A1) lösen, dann den hinteren Kotflügel (A) abnehmen.

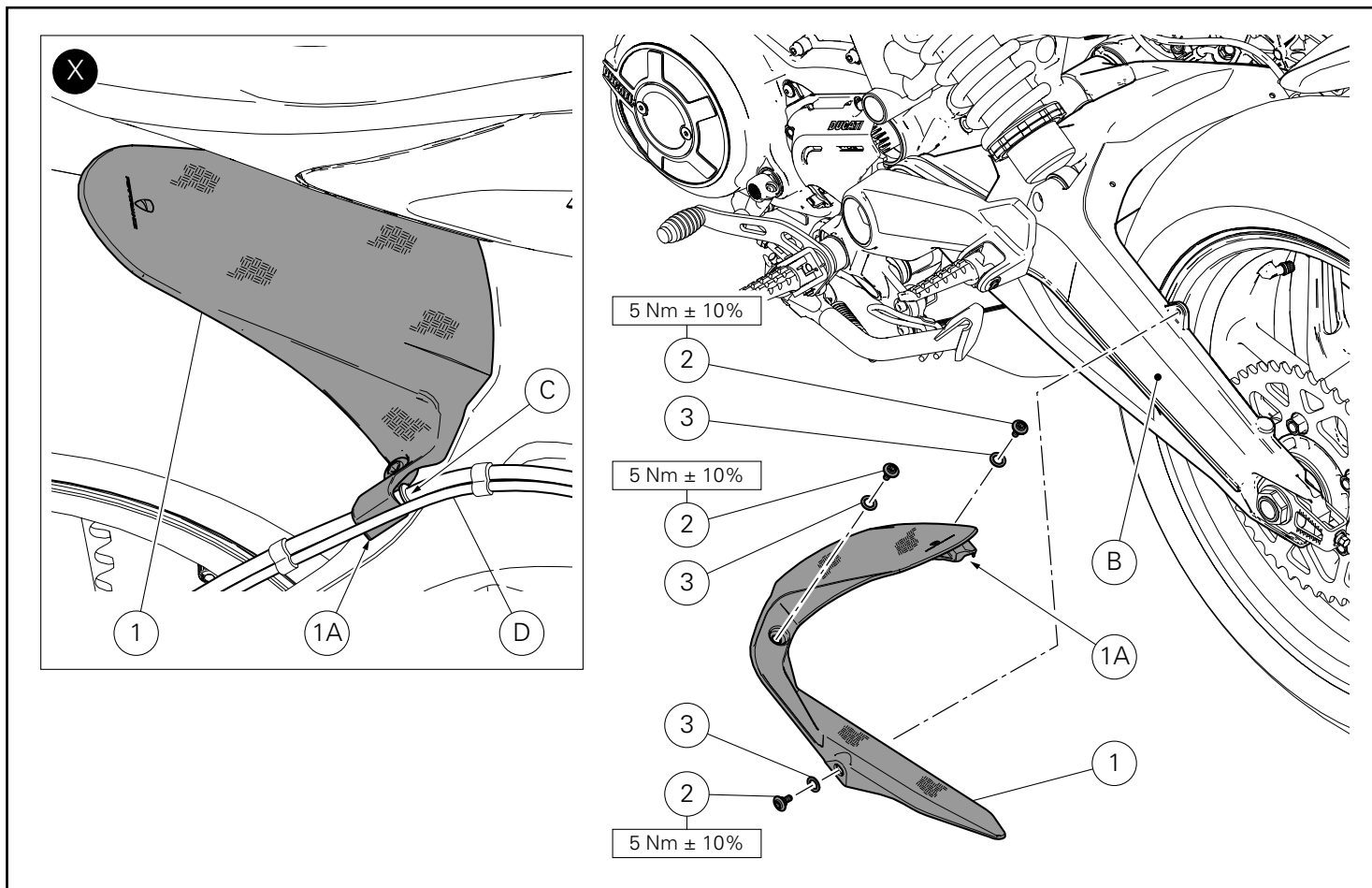

Pose composants kit

● Important

Vérifier, avant la pose, que tous les composants sont propres et en parfait état.

Adopter toutes les précautions nécessaires pour éviter d'endommager la surface externe des composants où on opère.

⚠ Attention

Durant la pose des composants en carbone, faire particulièrement attention au serrage des vis de fixation. Serrer les éléments de fixation sans forcer excessivement pour éviter que le carbone s'abîme.

Repose du garde-boue arrière

Introduire les 3 rondelles en nylon (3) sur le filet des 3 vis (2).

Appliquer du LOCTITE 243 sur le filet des 3 vis (1).

Positionner le garde-boue arrière en carbone (1) sur le bras oscillant (B) et présenter les 3 vis (A2).

S'assurer que le plot caoutchouc passe-tuyau (C) est positionné au-dessous du logement spécifique (1A) présent sur le garde-boue arrière en carbone (1).

● Important

Le câble du transmetteur de vitesse arrière (D) doit être positionné à l'extérieur du garde-boue en carbone (1) comme la figure (X) le montre.

Serrer les 3 vis (2) au couple prescrit.

Montage der Komponenten des Kits

● Wichtig

Vor der Montage überprüfen, dass sich alle Komponenten im sauberen und perfekten Zustand befinden.

Alle erforderlichen Vorsichtsmaßnahmen treffen, um eine Beschädigung der Oberflächen der Komponenten, die vom Eingriff betroffen sind, zu vermeiden.

⚠ Achtung

Während der Montage der Komponenten aus Kohlefaser ist besondere Aufmerksamkeit auf den Anzug der Befestigungsschrauben zu richten. Die Befestigungselemente ohne übermäßigen Kraftaufwand befestigen, um eine Beschädigung der Kohlefaserenteile zu vermeiden.

Montage des hinteren Kotflügels

Die 3 Nylon-Unterlegscheiben (3) auf das Gewinde der 3 Schrauben (2) fügen. LOCTITE 243 auf die Gewinde der 3 Schrauben (1) auftragen. Den hinteren Kotflügel aus Kohlefaser (1) an der Hinterradschwinge (B) anordnen und die 3 Schrauben (2) ansetzen. Sicherstellen, dass der Leitungsführungsgummi (C) unter der entsprechenden Aufnahme (1A) am hinteren Kotflügel aus Kotflügel (1) angeordnet ist.

● Wichtig

Das Kabel des Geschwindigkeitssensors (D) muss außen am Kotflügel aus Kohlefaser (1), wie auf Abbildung (X) dargestellt, angeordnet sein.

Die 3 Schrauben (2) mit dem angegebenen Anzugsmoment anziehen.

Conjunto do guarda-lamas traseiro em carbono Carbon rear mudguard kit



Símbolos

Para uma leitura rápida e racional, foram utilizados símbolos que evidenciam situações de máxima atenção, conselhos práticos ou simples informações. Preste muita atenção ao significado dos símbolos, pois a sua função é a de evitar a repetição de conceitos técnicos ou de avisos de segurança. Portanto, os símbolos devem ser considerados como verdadeiros "lembretes". Consulte esta página sempre que tiver dúvidas acerca do seu significado.



Atenção

O não cumprimento das instruções mostradas pode criar uma situação de perigo e causar graves lesões pessoais e até mesmo a morte.



Importante

Indica a possibilidade de causar danos ao veículo e/ou aos seus componentes se as instruções mostradas não forem executadas.



Notas

Fornecer informações úteis sobre a operação em curso.

Referências

Os detalhes evidenciados em cinza e com referência numérica (Ex. ①) representam o acessório a ser instalado e os eventuais componentes de montagem fornecidos como kit.

Os detalhes com referência alfabética (Ex. Ⓐ) representam os componentes originais presentes na moto.

Todas as indicações direita ou esquerda, referem-se ao sentido de marcha da moto.

Advertências gerais



Atenção

As operações mostradas nas páginas a seguir, se não forem executadas com boa técnica, podem prejudicar a segurança do condutor.



Atenção

As operações mostradas nas páginas a seguir, se não forem executadas com boa técnica, podem prejudicar a segurança do condutor.



Notas

Documentação necessária para executar a montagem do Conjunto: MANUAL DE OFICINA, relativo ao modelo de moto em sua posse.



Notas

Caso seja necessária a substituição de um componente do conjunto, consulte o quadro de peças de reposição em anexo.

Symbols

To allow quick and easy consultation, this manual uses graphic symbols to highlight situations in which maximum care is required, as well as practical advice or information.

Pay attention to the meaning of the symbols since they serve to avoid repeating technical concepts or safety warnings throughout the text. The symbols should therefore be seen as real reminders. Please refer to this page whenever in doubt as to their meaning.



Warning

Failure to follow these instructions might give rise to a dangerous situation and provoke severe personal injuries or even death.



Caution

Failure to follow these instructions might cause damages to the vehicle and/or its components.



Notes

Useful information on the procedure being described.

References

Parts highlighted in grey and with a numeric reference (Example ①) are the accessory to be installed and any assembly components supplied with the kit.

Parts with an alphabetic reference (Example Ⓐ) are the original components fitted on the vehicle.

Any right- or left-hand indication refers to the vehicle direction of travel.

General notes



Warning

Carefully perform the operations on the following pages since they might negatively affect rider safety.



Warning

Carefully perform the operations on the following pages since they might negatively affect rider safety.



Notes

The following documents are necessary for assembling the Kit: WORKSHOP MANUAL of your bike model.



Notes

Should it be necessary to change any kit parts, please refer to the attached spare part table.

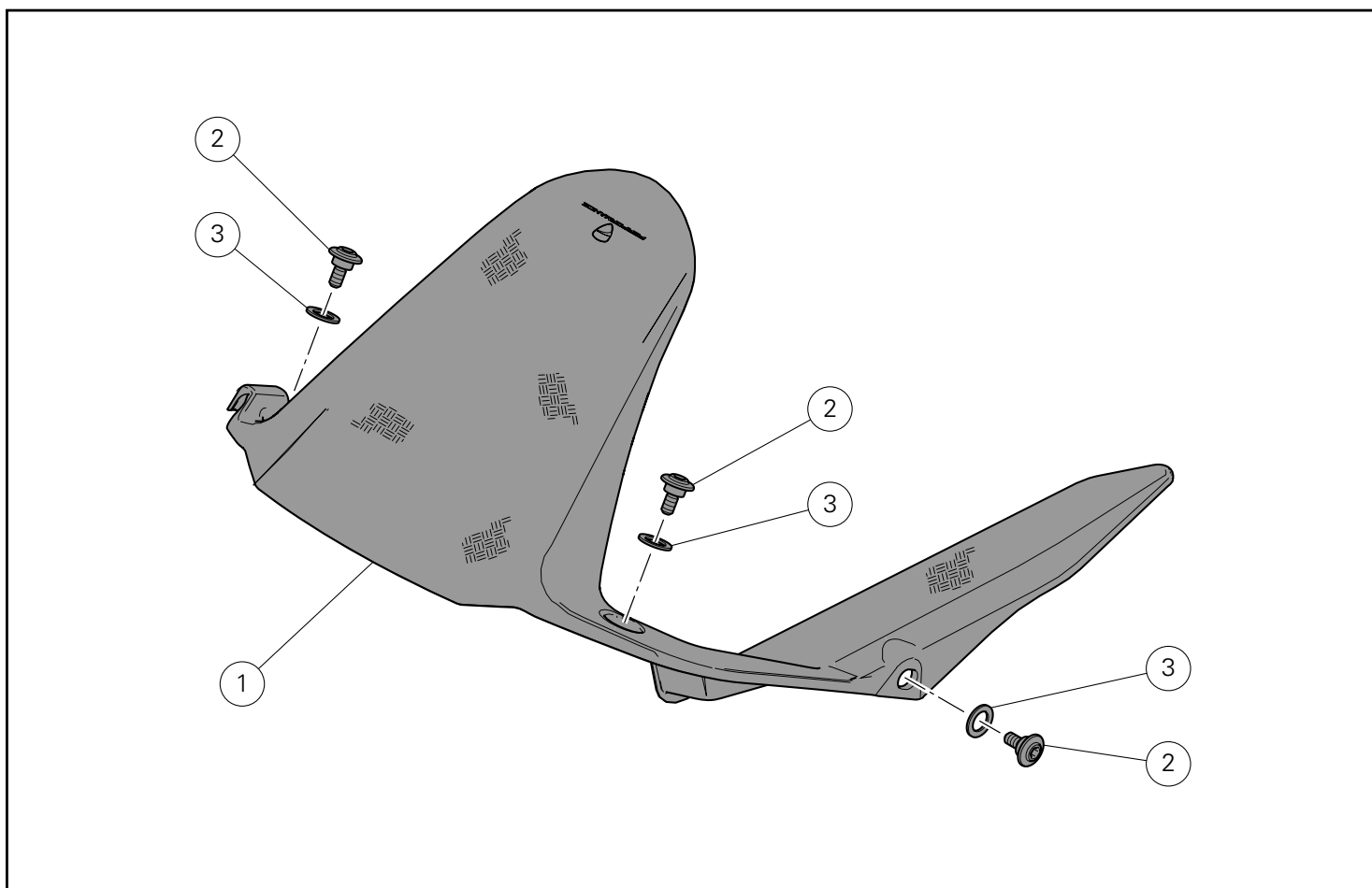

| Pos. | Descrição | Description |
|------|---|-------------------------|
| 1 | Guarda-lamas traseiro em carbono | Carbon rear mudguard |
| 2 | Parafuso especial de cabeça cilíndrica com sextavado interno M5X9 | Special TCEI screw M5x9 |
| 3 | Anilha de nylon | Nylon washer |

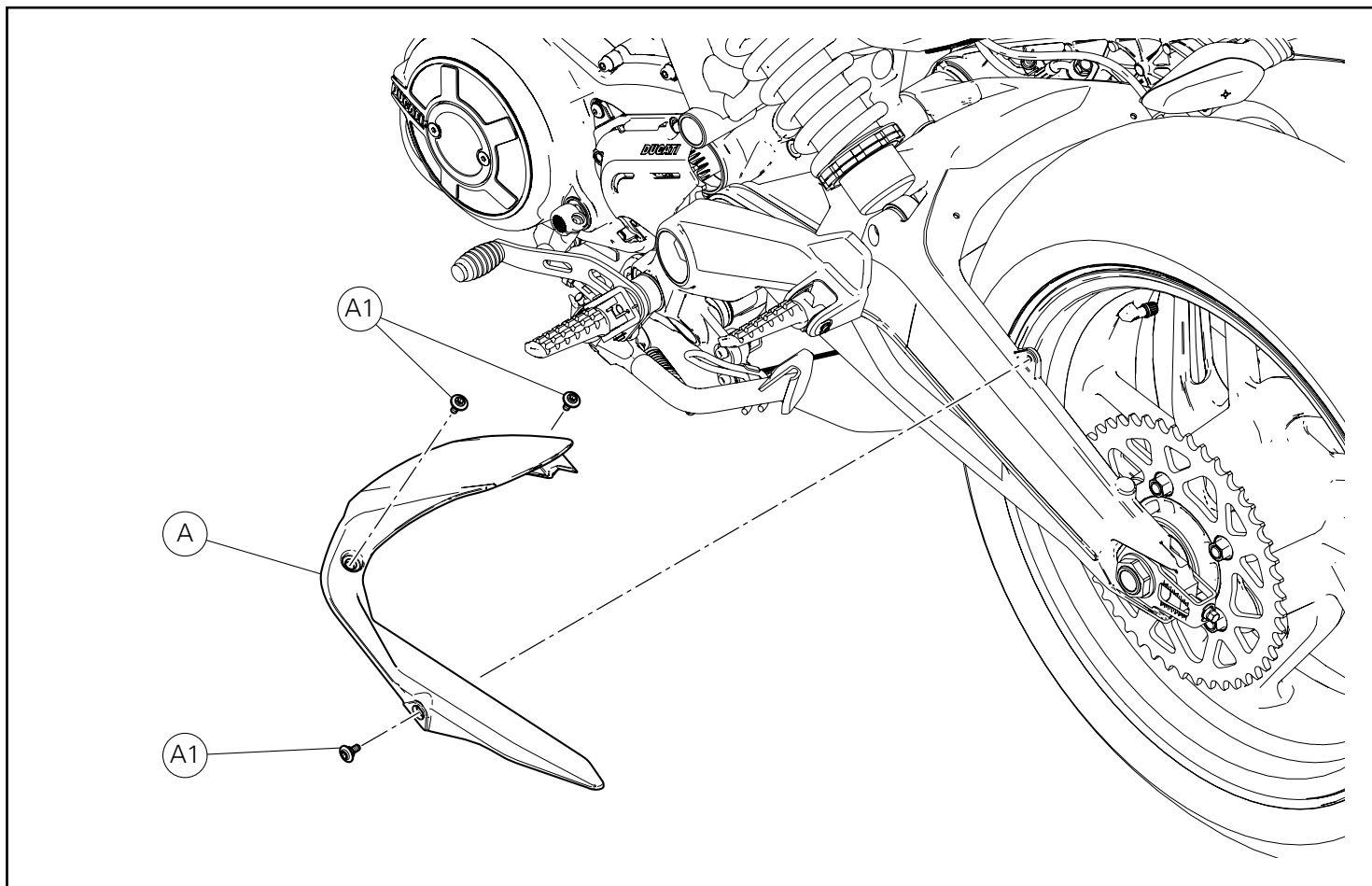

Desmontagem dos componentes originais

Removing the original components

Desmontagem do guarda-lamas traseiro

Removing the rear mudguard

Desatarraxe os 3 parafusos (A1) e remova o guarda-lamas traseiro (A).

Loosen no. 3 screws (A1) and remove rear mudguard (A).

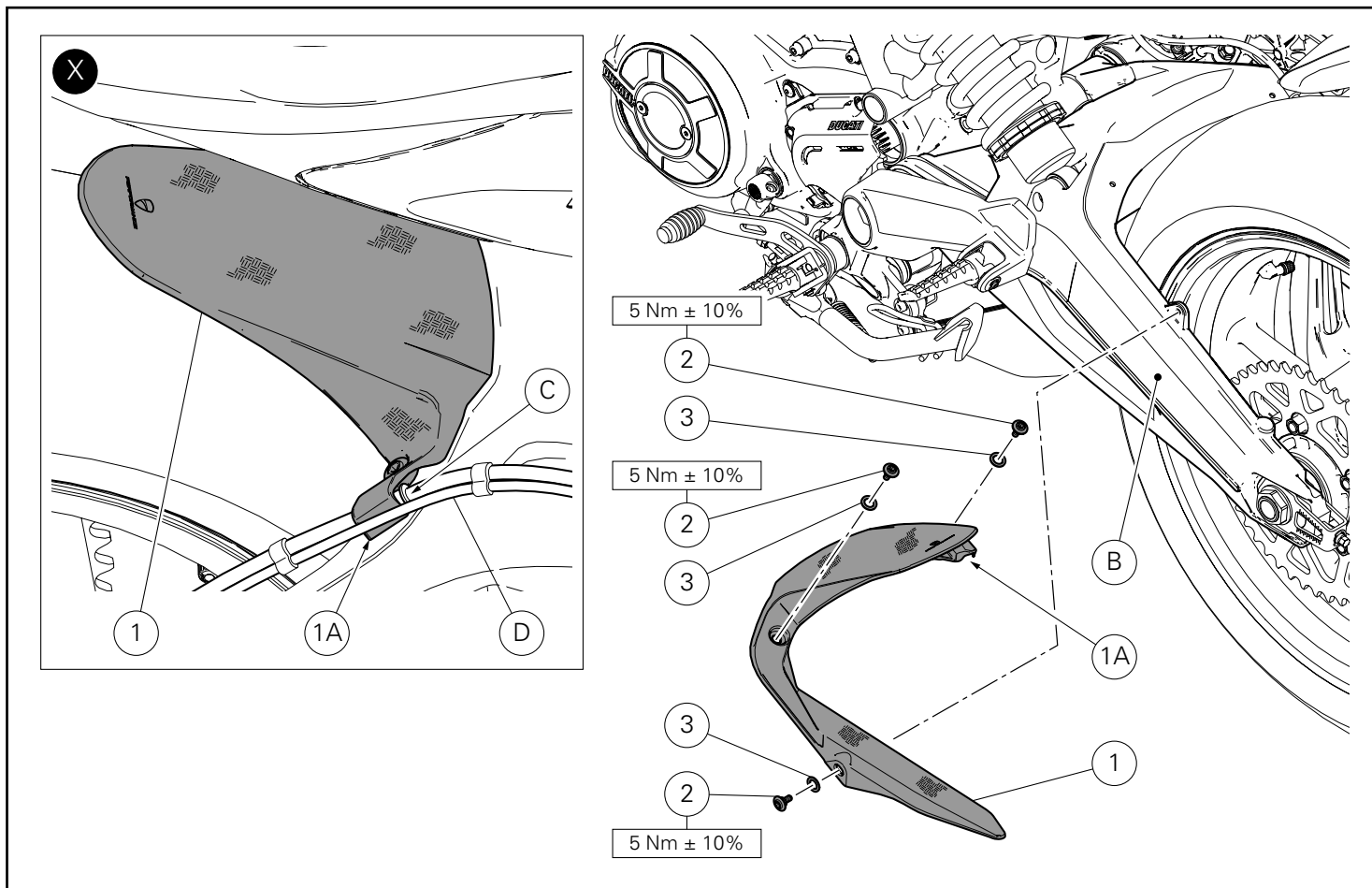

Montagem dos componentes

● Importante

Verifique, antes da montagem, se todos os componentes estão limpos e em perfeito estado.

Adote todas as precauções necessárias para evitar danificar qualquer peça com a qual deve trabalhar.

⚠ Atenção

Durante a montagem de componentes de carbono, preste especial atenção ao aperto dos parafusos de fixação.

Aperte os elementos de fixação sem forçar excessivamente, a fim de evitar que o carbono seja danificado.

Montagem do guarda-lamas traseiro

Insira as 3 anilhas de nylon (3) na rosca dos 3 parafusos (2).

Aplique LOCTITE 243 na rosca dos 3 parafusos (1).

Posicione o guarda-lamas traseiro em carbono (1) no braço oscilante (B) e encoste os 3 parafusos (2).

Certifique-se de que a borracha passa-tubos (C) está posicionada abaixo do respetivo alojamento (1A) presente no guarda-lamas traseiro em carbono (1).

● Importante

O cabo do sensor de velocidade traseiro (D) deve ser posicionado no exterior do guarda-lamas em carbono (1), como mostrado na figura (X).

Aperte os 2 parafusos (3) ao binário indicado.

Kit installation

● Caution

Check that all components are clean and in perfect condition before installation.

Adopt any precaution necessary to avoid damages to any part of the motorcycle you are working on.

⚠ Warning

When fitting carbon parts, take special care when tightening fastening screws.

Tighten fasteners without forcing too much to prevent carbon parts from being damaged.

Rear mudguard assembly

Insert no. 3 original nylon washers (3) on the thread of no. 3 screws (2).

Apply LOCTITE 243 on the thread of no.3 screws (1).

Position the rear carbon mudguard (1) on the swinging arm (B) and start no.3 screws (2).

Make sure that the hose grommet (C) is positioned under its housing (1A) on the rear carbon mudguard (1).

● Caution

The rear speed sensor cable (D) must be positioned on the outside of the carbon mudguard (1) as shown in the figure (X).

Tighten no.3 screws (2) to the specified torque.

Kit guardabarros trasero de carbono カーボン製リアマッドガードキット



Símbolos

Para una lectura rápida y racional se han empleado símbolos que evidencian situaciones de máxima atención, consejos prácticos o simples informaciones. Prestar mucha atención al significado de los símbolos porque su función consiste en omitir la repetición de conceptos técnicos o advertencias de seguridad. Los símbolos deben considerarse como verdaderos "apuntes". Consultar esta página cada vez que se tengan dudas sobre su significado.



Atención

El incumplimiento de las instrucciones indicadas puede crear una situación de peligro y ocasionar graves lesiones e incluso la muerte.



Importante

Indica la posibilidad de provocar un daño al vehículo y/o a sus componentes si no se siguen las instrucciones indicadas.



Notas

Suministra útiles informaciones sobre la operación en curso.

Referencias

Las partes resaltadas en gris y la referencia numérica (Por ej. ①) representan el accesorio que se debe instalar y los eventuales componentes de montaje suministrados en el kit.

Las partes con referencia alfabética (Por ej. Ⓐ) representan los componentes originales presentes en la motocicleta.

Todas las indicaciones derecha o izquierda se refieren al sentido de marcha de la motocicleta.

Advertencias generales



Atención

Las operaciones descritas en las siguientes páginas deben realizarse correctamente para no perjudicar la seguridad del piloto.



Atención

Las operaciones descritas en las siguientes páginas deben realizarse correctamente para no perjudicar la seguridad del piloto.



Notas

La documentación necesaria para realizar el montaje del Kit es el: MANUAL DE TALLER, relativo al modelo de moto en vuestro poder.



Notas

Si fuera necesario sustituir un componente del kit, consultar la tabla de recambios adjunta.

シンボル

素早くかつ合理的に読み進めることができるように、本マニュアルではいくつかのシンボルを導入し、最大限の注意を払う必要がある状況や、推奨事項、または一般情報を明確にしています。技術的概念や安全に関する警告を繰り返し記載する必要がないように機能しているので、各シンボルの意味に十分注意してください。シンボルは、実際上の“覚え書き”であると考えてください。シンボルなどの意味がわからなくなったり疑問に思う場合は、必ずこのページで調べるようにしてください。



注記

この説明書に従わずに使用すると危険な状況を招き、重大なけが、あるいは死をももたらす原因となることがあります。



重要

この説明書に従わずに使用すると、車体及び/ 又はその部品に損害を招く可能性があります



参考

操作中の内容に関する有用な情報を掲載しています。

参照

灰色で表示する部品、および参照番号 (Es. ①) で表示する部品は、キットに付属する取り付け部品および組み立て部品を示します。

参照アルファベット (Es. Ⓐ) で表示する部品は、車両に付属するオリジナル部品を示します。

すべての右及び左の指示は車体の進行方向を向いたものです。

一般警告事項



注記

以下のページに記載されている作業が規定通りに実施されないと、ライダーの安全性を脅かすおそれがあります。



注記

以下のページに記載されている作業が規定通りに実施されないと、ライダーの安全性を脅かすおそれがあります。



参考

キットの取り付けに必要な資料：お手持ちの車両モデルに対応するワークショップマニュアル。



参考

キットの部品を交換する必要がある場合は、添付のスペアパーツ表を参照してください。

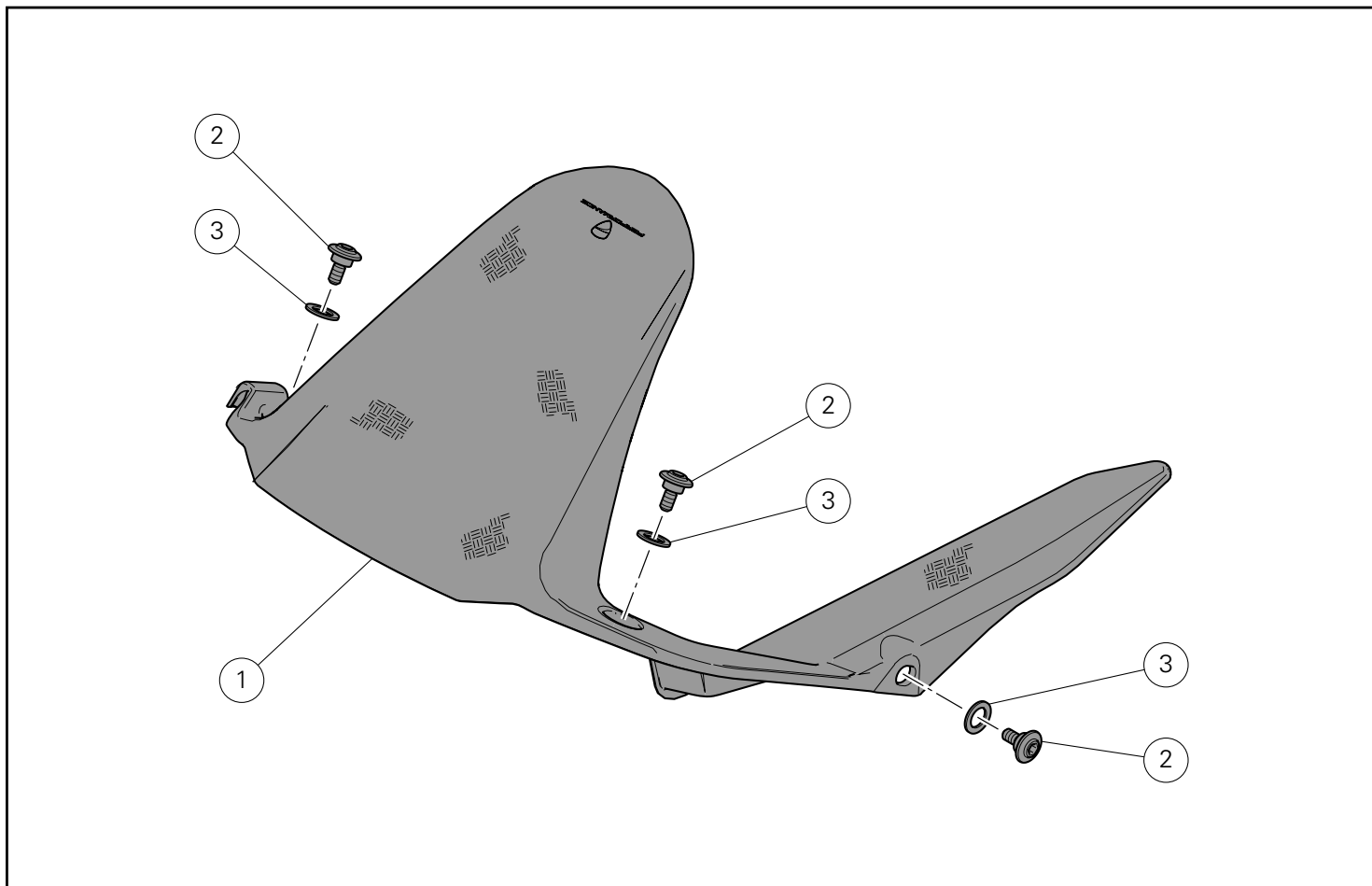

| Pos. | Descripció | 説明 |
|------|---------------------------------|-------------------|
| 1 | Guardabarros trasero de carbono | カーボン製リアマッドガード |
| 2 | Tornillo especial TCEI M5X9 | 専用スクリュー TCEI M5x9 |
| 3 | Arandela de nylon | ナイロンワッシャー |

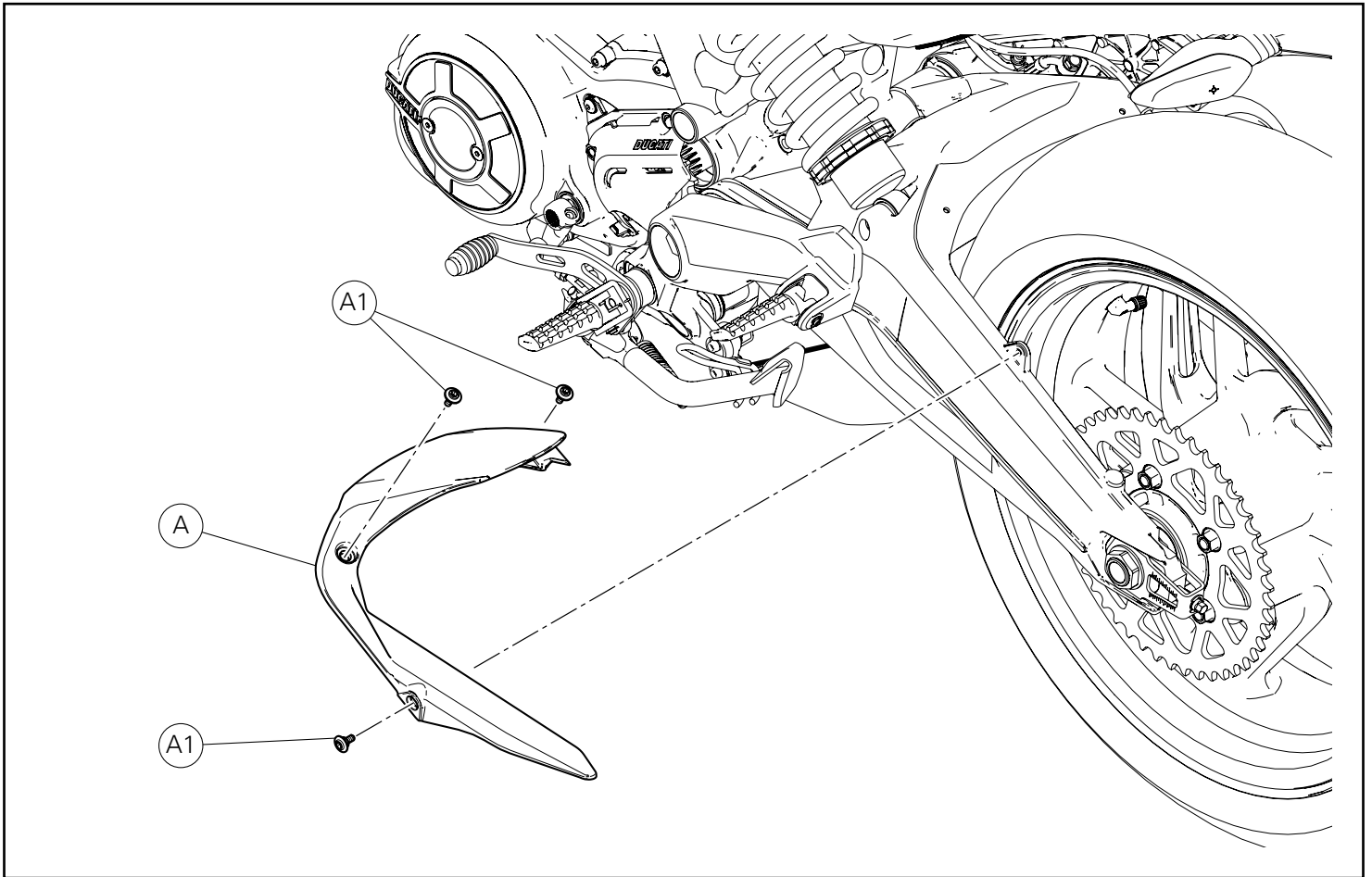

Desmontaje componentes originales

オリジナル部品の取り外し

Desmontaje guardabarros trasero

リアマッドガードの取り外し

Desatornillar los 3 tornillos (A1) y quitar el guardabarros trasero (A).

3 本のスクリュー (A1) を緩めて外し、リアマッドガード (A) を取り外します。

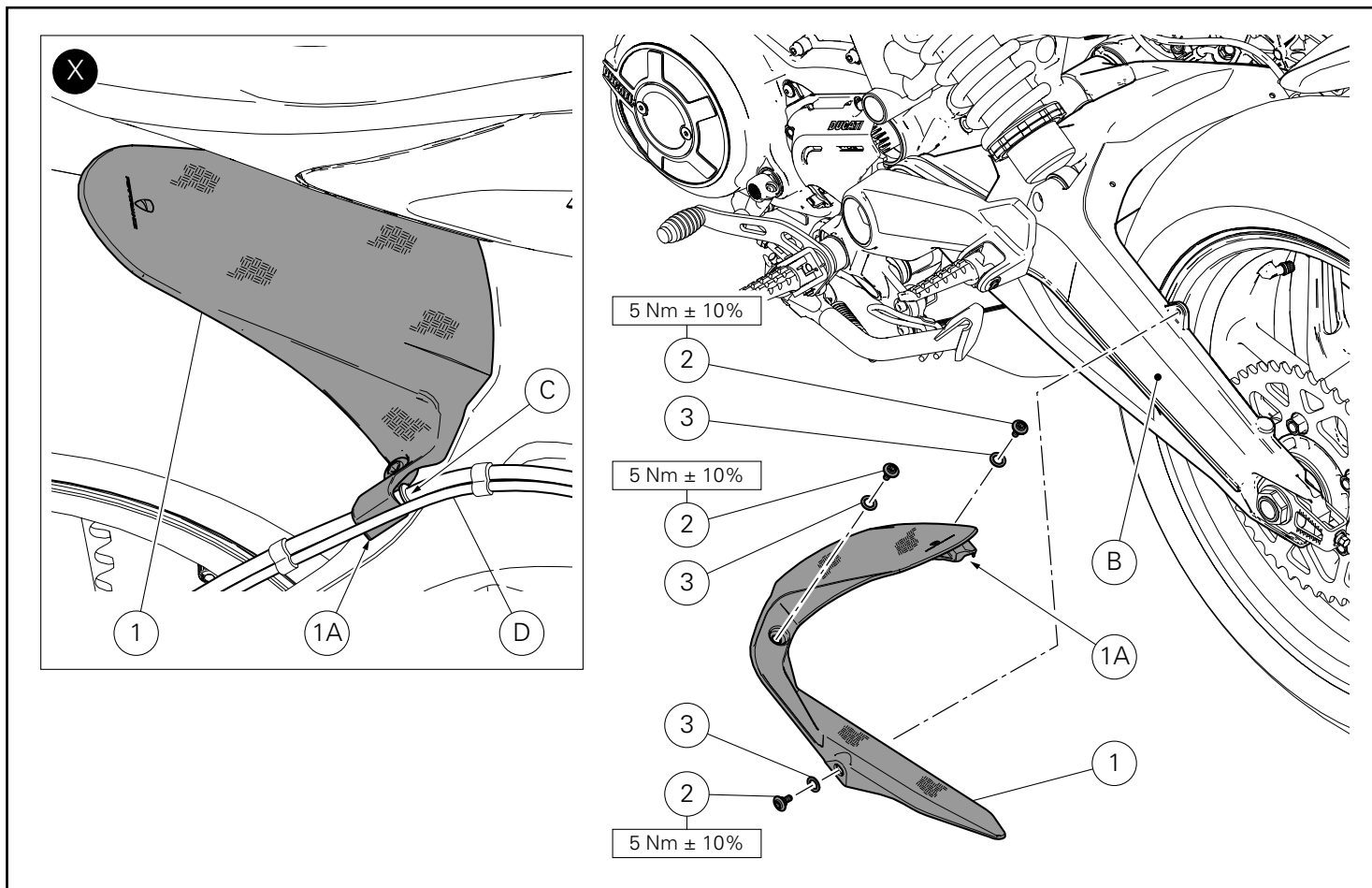

Montaje componentes kit

● Importante

Controlar, antes del montaje, que todos los componentes se encuentren limpios y en perfecto estado. Adoptar todas las precauciones necesarias para evitar daños en la superficie exterior de los componentes donde se debe operar.

⚠ Atención

Durante el montaje de componentes de carbono, poner particular atención en el ajuste de los tornillos de fijación. Ajustar los elementos de fijación sin forzar excesivamente, para evitar que el carbono se dañe.

Montaje guardabarros trasero

Introducir las 3 arandelas de nylon (3) en la rosca de los 3 tornillos (2).

Aplicar LOCTITE 243 en la rosca de los 3 tornillos (1).

Posicionar el guardabarros trasero de carbono (1) en el basculante (B) e introducir los 3 tornillos (2).

Asegurarse de que la goma pasatubo (C) se encuentre por debajo de la específica sede (1A) en el guardabarros trasero de carbono (1).

● Importante

El cable del sensor de velocidad trasero (D) debe estar colocado por la parte exterior del guardabarros de carbono (1), como ilustra la figura (X).

Ajustar los 3 tornillos (2) al par de apriete indicado.

キット部品の取り付け

● 重要

取り付け前にすべての部品に汚れがなく、完璧な状態であることを確認します。作業する部品の外側表面を傷つけないために、必要な予防措置を取ってください。

⚠ 注記

カーボン製部品の取り付けの際は、固定用スクリューの締め付けに十分注意してください。カーボン素材を損傷しないよう、固定部品の過度な締め付けはおこなわないでください。

リアマッドガードの取り付け

3個のナイロンワッシャー (3) を 3本のスクリュー (2) のネジ山に取り付けます。

3本のスクリュー (1) のネジ山に LOCTITE 243 を塗布します。カーボン製リアマッドガード (1) をスイングアーム (B) に配置し、3本のスクリュー (2) を差し込みます。

ホースガイドラバー (C) がカーボン製リアマッドガード (1) の所定のハウジング (1A) の下に配置されていることを確認してください。

● 重要

図 (X) に示すように、リアスピードセンサーケーブル (D) はカーボン製リアマッドガード (1) の外側に配置してください。

3本のスクリュー (2) を規定のトルクで締め付けます。



DUCATI PERFORMANCE accessories

レース専用部品 ご注文書

ご注文商品

1 P/N

商品名

2 P/N

商品名

3 P/N

商品名

4 P/N

商品名

5 P/N

商品名

お客様ご記入欄

私は上記レース専用部品を下記車両に装着し、サーキット走行のみに利用し、一般公道には利用しません。

車台番号 ZDM

モデル名

お客様署名

ご注文日

ドゥカティ正規ネットワーク店記入欄

お客様に上記レース専用部品を販売し、レース専用部品のご利用方法を説明いたしました。

販売店署名

販売日

年

月

日

販売店様へお願い

- 上記ご記入の上、弊社アフターセールス部までFAXしてください。FAX:03-6692-1317
- 取り付け車両1台に1枚でご使用ください。



Kit parafango posteriore in carbonio / Carbon rear mudguard kit / Kit garde-boue arrière en carbone / Kit hinterer Kotflügel aus Kohle-
faser / Conjunto do guarda-lamas traseiro em carbono / Kit guardabarros trasero de carbono / カーボン製リアマッドガードキット

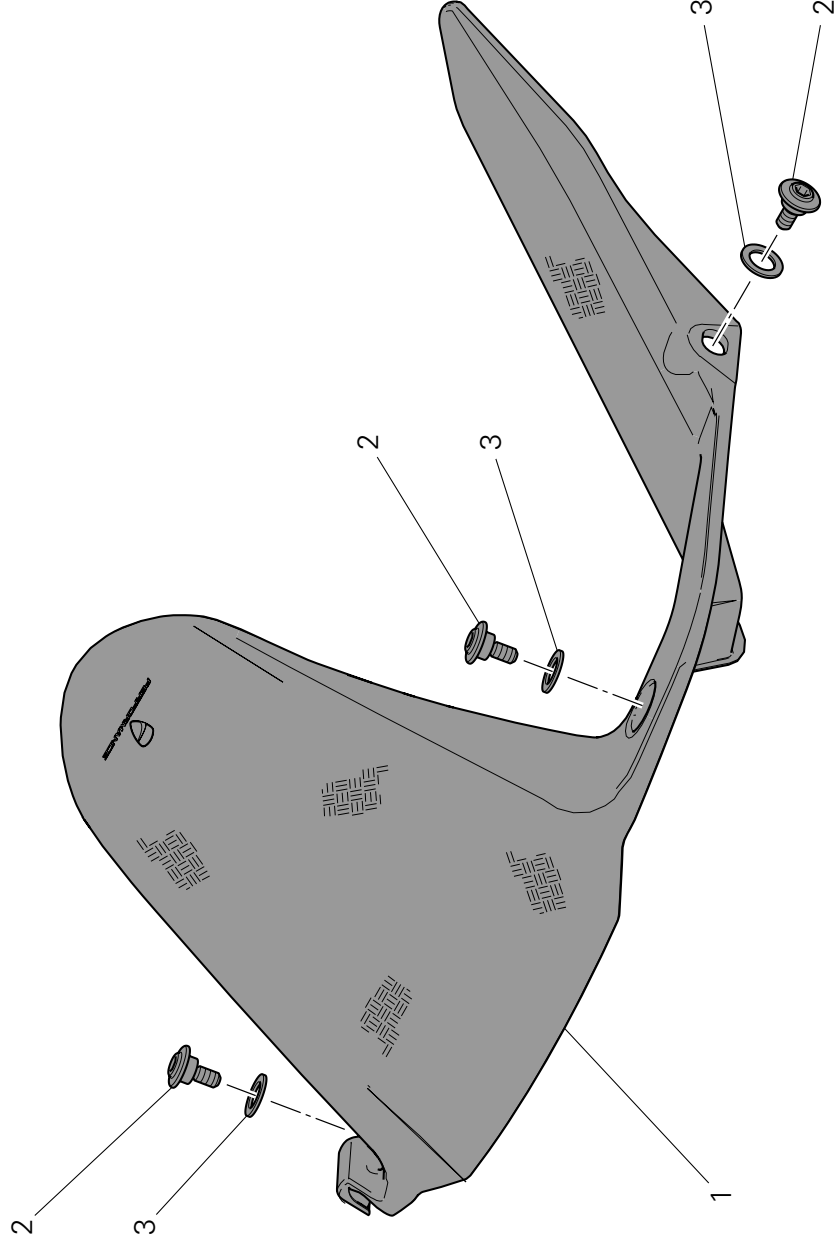

| Pos. | Cod. | Denominazione | Description | Designation | Bezeichnung | Descrição | Denominación | 説明 | Q.ty |
|------|------------|----------------------------------|-------------------------|-------------------------------|-------------------------------------|---|---------------------------------|-------------------|------|
| 1 | 96910931AA | Parafango posteriore in carbonio | Carbon rear mudguard | Garde-boue arrière en carbone | Hinterer Kotflügel aus Kohlefaser | Guarda-lamas traseiro em carbono | Guardabarros trasero de carbono | カーボン製リアマツドガード | 1 |
| 2 | 77210852C | Vite speciale TCEI M5x9 | Special TCEI screw M5x9 | Vis spéciale TCHC M5x9 | Spezial-Innensechskantschraube M5x9 | Parafuso especial de cabeça cilíndrica com sextavado interno M5X9 | Tornillo especial TCEI M5X9 | 専用スクリュー TCEI M5x9 | 3 |
| 3 | 85611281A | Rosetta in nylon | Nylon washer | Rondelle en nylon | Unterlegscheibe aus Nylon | Anilha de nylon | Arandela de nylon | ナイロンワッシャー | 3 |