

Kit protezione catena inferiore Lower chain protection kit



Simbologia

Per una lettura rapida e razionale sono stati impiegati simboli che evidenziano situazioni di massima attenzione, consigli pratici o semplici informazioni.

Prestare molta attenzione al significato dei simboli, in quanto la loro funzione è quella di non dovere ripetere concetti tecnici o avvertenze di sicurezza. Sono da considerare, quindi, dei veri e propri "promemoria".

Consultare questa pagina ogni volta che sorgeranno dubbi sul loro significato.



Attenzione

La non osservanza delle istruzioni riportate può creare una situazione di pericolo e causare gravi lesioni personali e anche la morte.



Importante

Indica la possibilità di arrecare danno al veicolo e/o ai suoi componenti se le istruzioni riportate non vengono eseguite.



Note

Fornisce utili informazioni sull'operazione in corso.

Riferimenti

I particolari evidenziati in grigio e riferimento numerico (Es. ①) rappresentano l'accessorio da installare e gli eventuali componenti di montaggio forniti a kit.

I particolari con riferimento alfabetico (Es. A) rappresentano i componenti originali presenti sul motoveicolo.

Tutte le indicazioni destro o sinistro si riferiscono al senso di marcia del motociclo.

Avvertenze generali



Attenzione

Le operazioni riportate nelle pagine seguenti devono essere eseguite da un tecnico specializzato o da un'officina autorizzata DUCATI.



Attenzione

Le operazioni riportate nelle pagine seguenti se non eseguite a regola d'arte possono pregiudicare la sicurezza del pilota.



Note

Documentazione necessaria per eseguire il montaggio del Kit è il MANUALE OFFICINA, relativo al modello di moto in vostro possesso.



Note

Nel caso fosse necessaria la sostituzione di un componente del kit consultare la tavola ricambi allegata.

Symbols

To allow quick and easy consultation, this manual uses graphic symbols to highlight situations in which maximum care is required, as well as practical advice or information.

Pay attention to the meaning of the symbols since they serve to avoid repeating technical concepts or safety warnings throughout the text. The symbols should therefore be seen as real reminders. Please refer to this page whenever in doubt as to their meaning.



Warning

Failure to follow these instructions might give rise to a dangerous situation and provoke severe personal injuries or even death.



Caution

Failure to follow these instructions might cause damages to the vehicle and/or its components.



Notes

Useful information on the procedure being described.

References

Parts highlighted in grey and with a numeric reference (Example ①) are the accessory to be installed and any assembly components supplied with the kit.

Parts with an alphabetic reference (Example A) are the original components fitted on the vehicle.

Any right- or left-hand indication refers to the vehicle direction of travel.

General notes



Warning

Carefully perform the operations on the following pages since they might negatively affect rider safety.



Warning

Carefully perform the operations on the following pages since they might negatively affect rider safety.



Notes

The following documents are necessary for assembling the Kit: WORKSHOP MANUAL of your bike model.



Notes

Should it be necessary to change any kit parts, please refer to the attached spare part table.

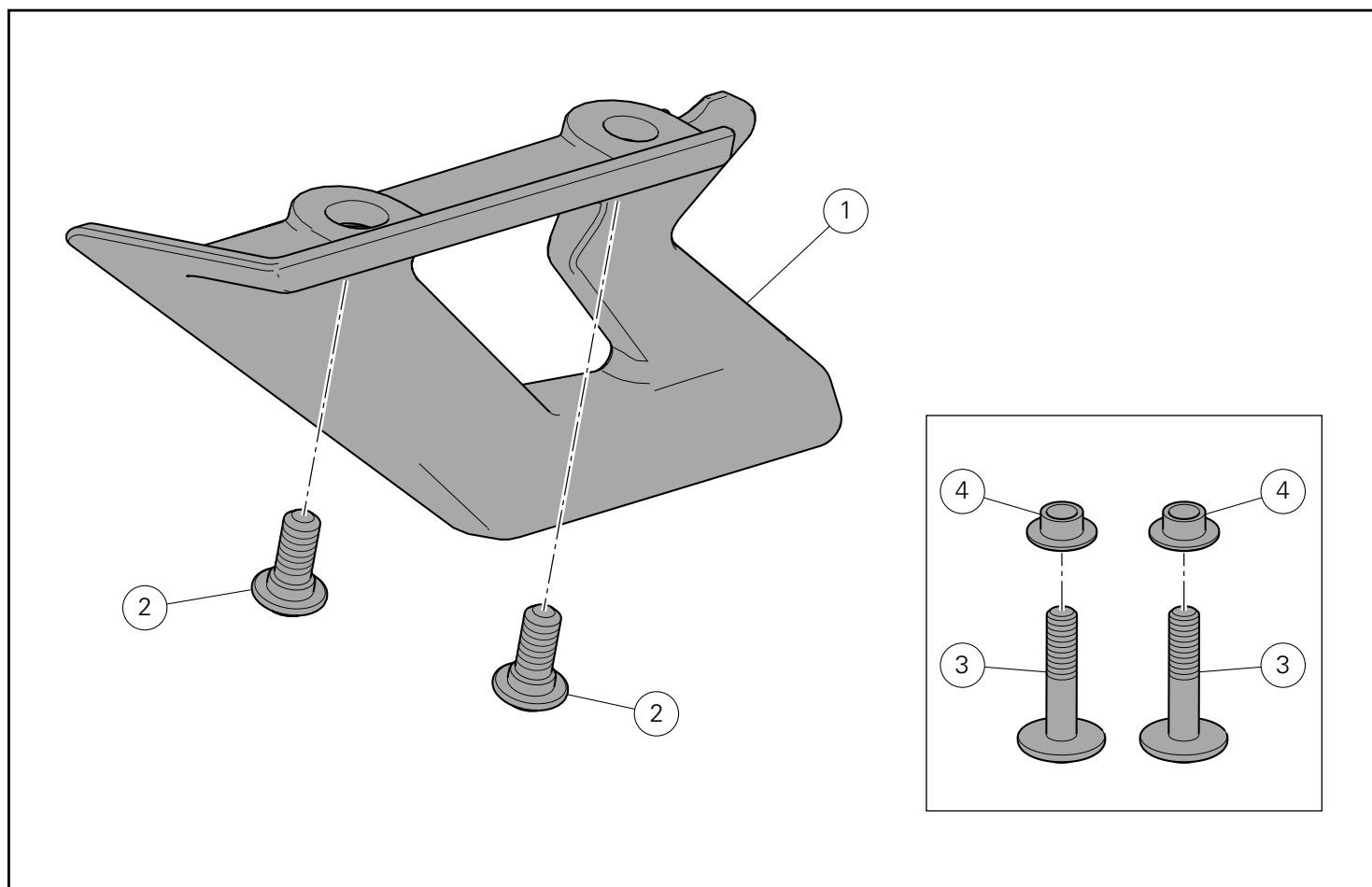

Pos.	Denominazione	Description
1	Paracatena inferiore	Lower chain guard
2	Vite TBEI M6x16	TBEI screw M6x16
3	Vite spec. TCEI M5x22	Spec. screw TCEI M5x22
4	Distanziale con collare	Spacer with collar

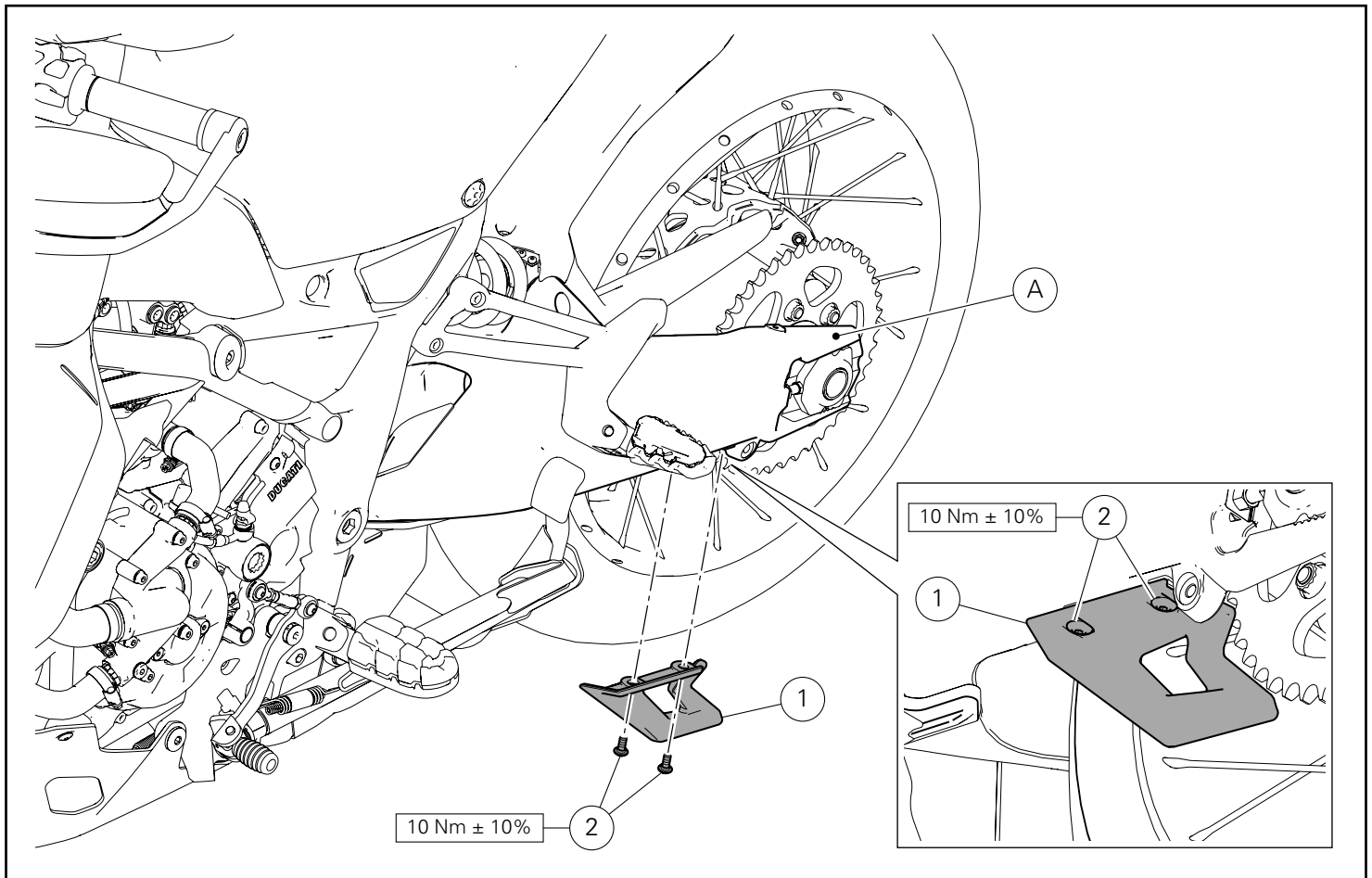

Montaggio componenti kit

● Importante

Verificare, prima del montaggio, che tutti i componenti risultino puliti e in perfetto stato.
Adottare tutte le precauzioni necessarie per evitare di danneggiare qualsiasi parte nella quale ci si trova ad operare.

Montaggio protezione catena inferiore su forcellone con fori M6

Operando sul lato sinistro del motoveicolo, posizionare la protezione (1) sul forcellone (A) e impuntare dal basso le n.2 viti (2). Serrare le n.2 viti (2) alla coppia indicata.

Kit installation

● Caution

Check that all components are clean and in perfect condition before installation.
Adopt any precaution necessary to avoid damages to any part of the motorcycle you are working on.

Lower chain protection assembly on swinging arm with M6 holes

Working on the left side of the motorcycle, fit the protection (1) on the swinging arm (A) and start no.2 screws from the bottom (2). Tighten the no. 2 screws (2) to the specified torque.

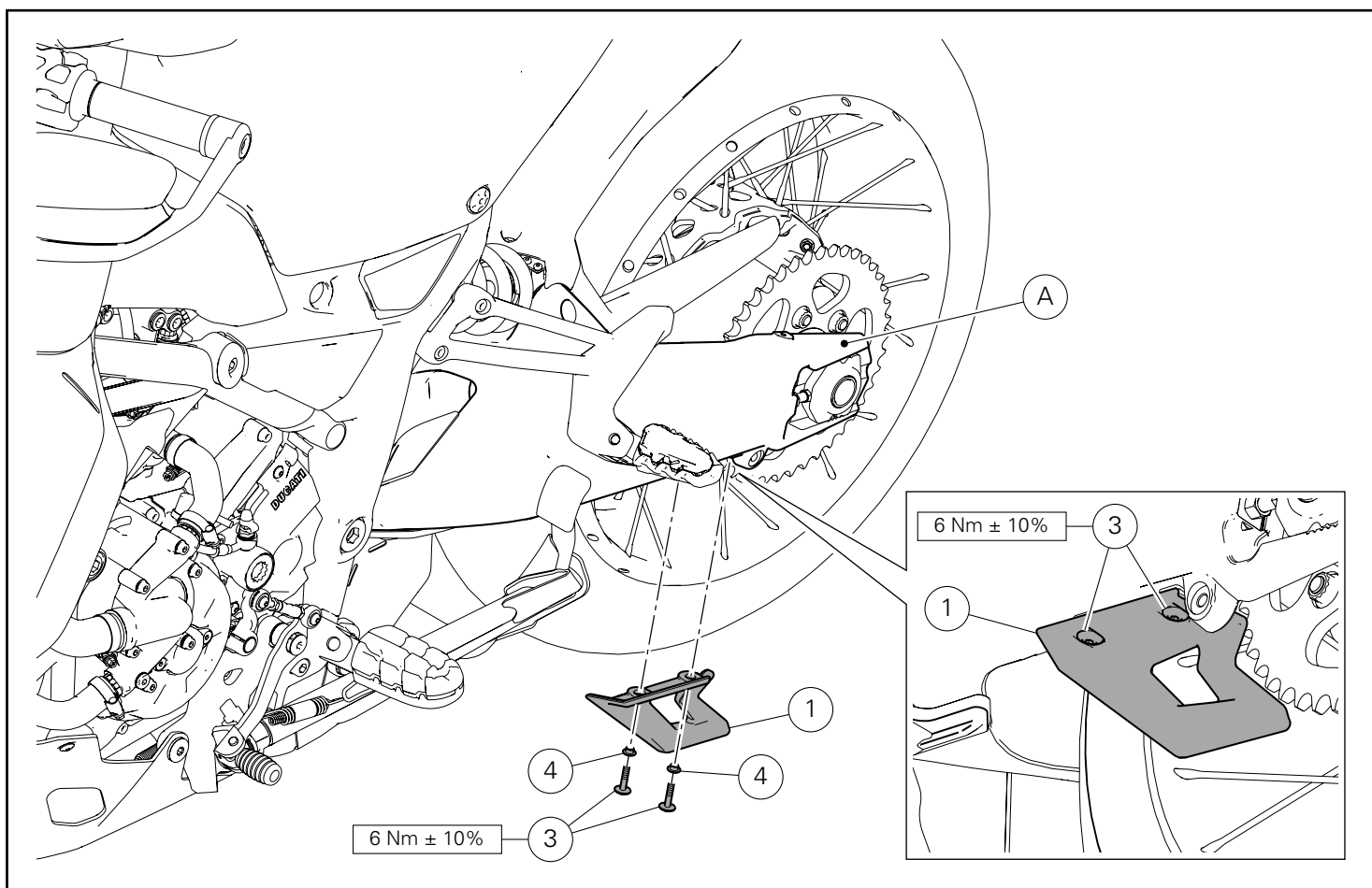

Montaggio protezione catena inferiore su forcellone con fori M5

Premontare i n.2 distanziali con collare (4) sulle n.2 viti (3).
Operando sul lato sinistro del motoveicolo, posizionare la protezione (1) sul forcellone (A) e impuntare dal basso le n.2 viti (3).
Serrare le n.2 viti (3) alla coppia indicata.

Lower chain protection assembly on swinging arm with M5 holes

Pre-assemble no. 2 spacers with collar (4) on no. 2 screws (3).
Working on the left side of the motorcycle, fit the protection (1) on the swinging arm (A) and start no.2 screws from the bottom (3).
Tighten the no. 2 screws (3) to the specified torque.

Kit protection chaîne inférieure Kit unterer Kettenschutz



Symboles

Pour faciliter la consultation de ce manuel, des symboles signalent des situations exigeant le maximum d'attention, des conseils pratiques ou de simples informations. Lire attentivement la signification de ces symboles car ils renvoient à des concepts techniques ou des consignes de sécurité de la plus grande importance. Ils doivent être considérés comme de véritables « aide-mémoire ». Toujours consulter cette page en cas de doute concernant leur signification.



Attention

La non-observance des instructions reportées ci-dessous peut créer une situation dangereuse et provoquer de graves lésions personnelles voire la mort.



Important

Indique la possibilité d'endommager le véhicule et/ou ses composants si les instructions reportées ci-dessous ne sont pas suivies.



Remarques

Fournit des informations utiles sur l'opération en cours.

Références

Les pièces surlignées en gris et la référence numérique (Ex. ①) représentent l'accessoire à installer et les composants de montage éventuels fournis en kit.

Les pièces avec référence alphabétique (Ex. Ⓐ) représentent les composants d'origine présents sur le motorcycle.

Toutes les indications droite ou gauche se réfèrent au sens de marche la moto.

Avertissements généraux



Attention

Les opérations indiquées dans les pages suivantes, au cas où elles ne seraient pas effectuées selon les règles de l'art pourraient compromettre la sécurité du pilote.



Attention

Les opérations indiquées dans les pages suivantes, au cas où elles ne seraient pas effectuées selon les règles de l'art pourraient compromettre la sécurité du pilote.



Remarques

La documentation nécessaire pour effectuer la pose du Kit est le : MANUEL D'ATELIER, relatif au modèle de moto en votre possession.



Remarques

Au cas où il serait nécessaire d'effectuer le remplacement d'un composant du kit, il faudra consulter la planche relative aux pièces détachées ci-jointe.

Symbole

Zum schnellen und übersichtlichen Lesen werden Symbole verwendet, die außerordentlich wichtige Situationen, praktische Ratschläge oder auch nur einfache Informationen hervorheben. Der Bedeutung dieser Symbole ist besondere Aufmerksamkeit zu schenken, da sich hierdurch das ständige Wiederholen von technischen Konzepten oder Sicherheitshinweisen erübrigt. Sie stellen daher regelrechte „Merker“ dar. Diese Seite ist immer dann zur Hand zu nehmen, wenn Zweifel über die Bedeutung eines Symbols bestehen sollten.



Achtung

Eine Nichtbeachtung der hier wiedergegebenen Anweisungen kann Gefahrensituationen schaffen und zu schweren Verletzungen und auch zum Tod führen.



Wichtig

Weist darauf hin, dass bei Nichteinhaltung der hier wiedergegebenen Anweisungen die Möglichkeit für Schäden am Fahrzeug und/oder seiner Komponenten besteht.



Hinweis

Übermittelt nützliche Informationen zum betreffenden Arbeitseingriff.

Bezugsangaben

Die grau gekennzeichneten Bestandteile mit numerischem Bezug (Bsp. ①) geben das zu installierende Bestandteil und die eventuellen, im Kit enthaltenen Montagekomponenten wieder.

Die Bestandteile mit alphabetischem Bezug (Bsp. Ⓐ) geben die Original-Bestandteile wieder, die am Motorrad verbaut wurden.

Alle Angaben wie „rechts“ oder „links“ beziehen sich auf die Fahrtrichtung des Motorrads.

Allgemeine Warnhinweise



Achtung

Werden die auf den folgenden Seiten beschriebenen Arbeitsmaßnahmen nicht fachgerecht ausgeführt, kann sich dies auf die Sicherheit des Fahrers auswirken.



Achtung

Werden die auf den folgenden Seiten beschriebenen Arbeitsmaßnahmen nicht fachgerecht ausgeführt, kann sich dies auf die Sicherheit des Fahrers auswirken.



Hinweis

Für die Montage des Kits sind folgende Unterlagen erforderlich: WERKSTATTHANDBUCH, des sich in Ihrem Besitz befindlichen Motorrads.



Hinweis

Sollte sich der Austausch eines Bestandteils des Kits als erforderlich erweisen, ist dazu Bezug auf die beiliegende Ersatzteilliste zu nehmen.

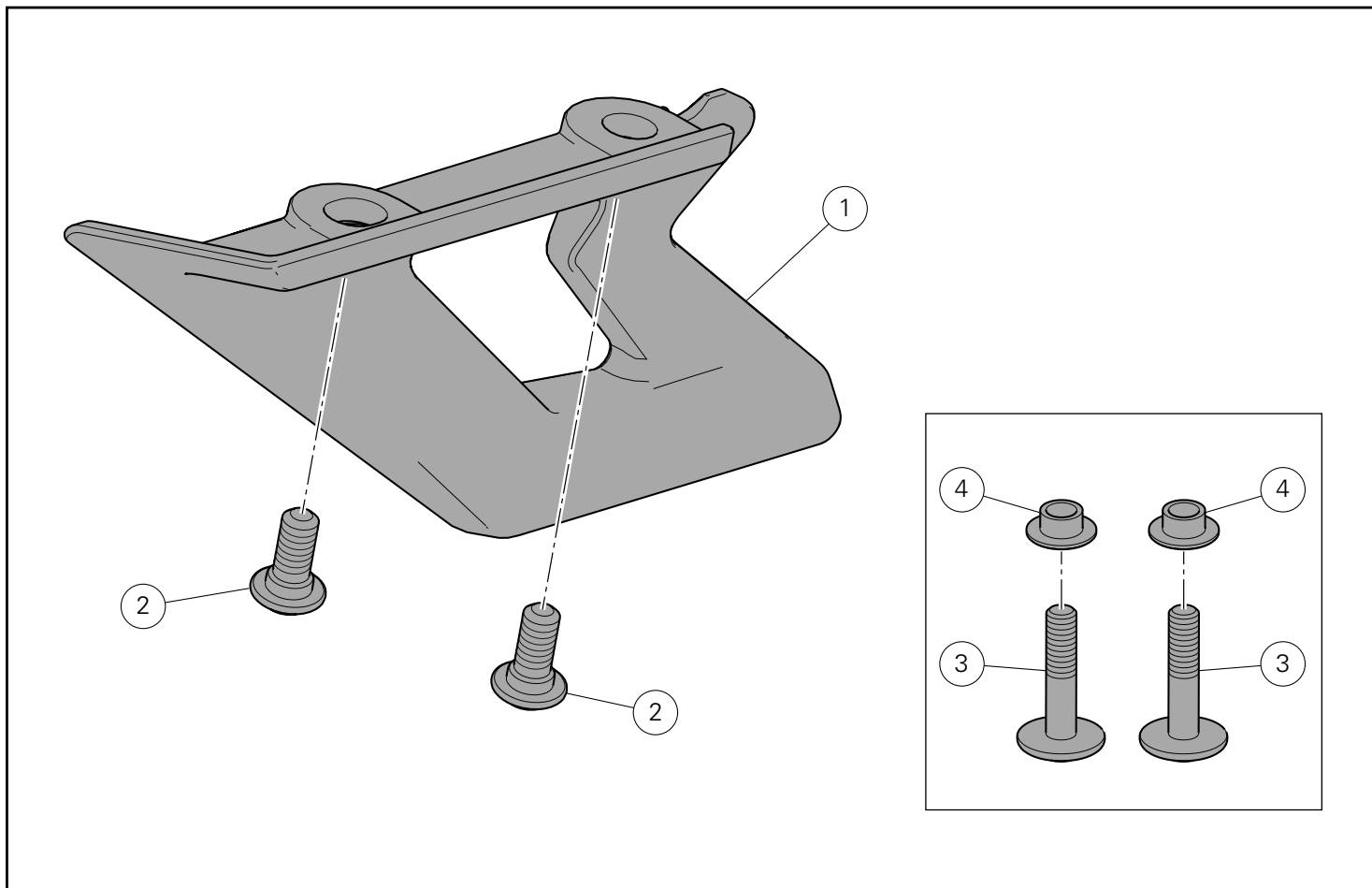

Pos.	Designation	Bezeichnung
1	Cache-chaîne inférieur	Unterer Kettenschutz
2	Vis TBHC M6x16	Linseninnensechskantschraube M6x16
3	Vis spéc. TCHC M5x22	Spez.schraube mit Innensechskant M5x22
4	Entretoise à collerette	Distanzstück mit Bund

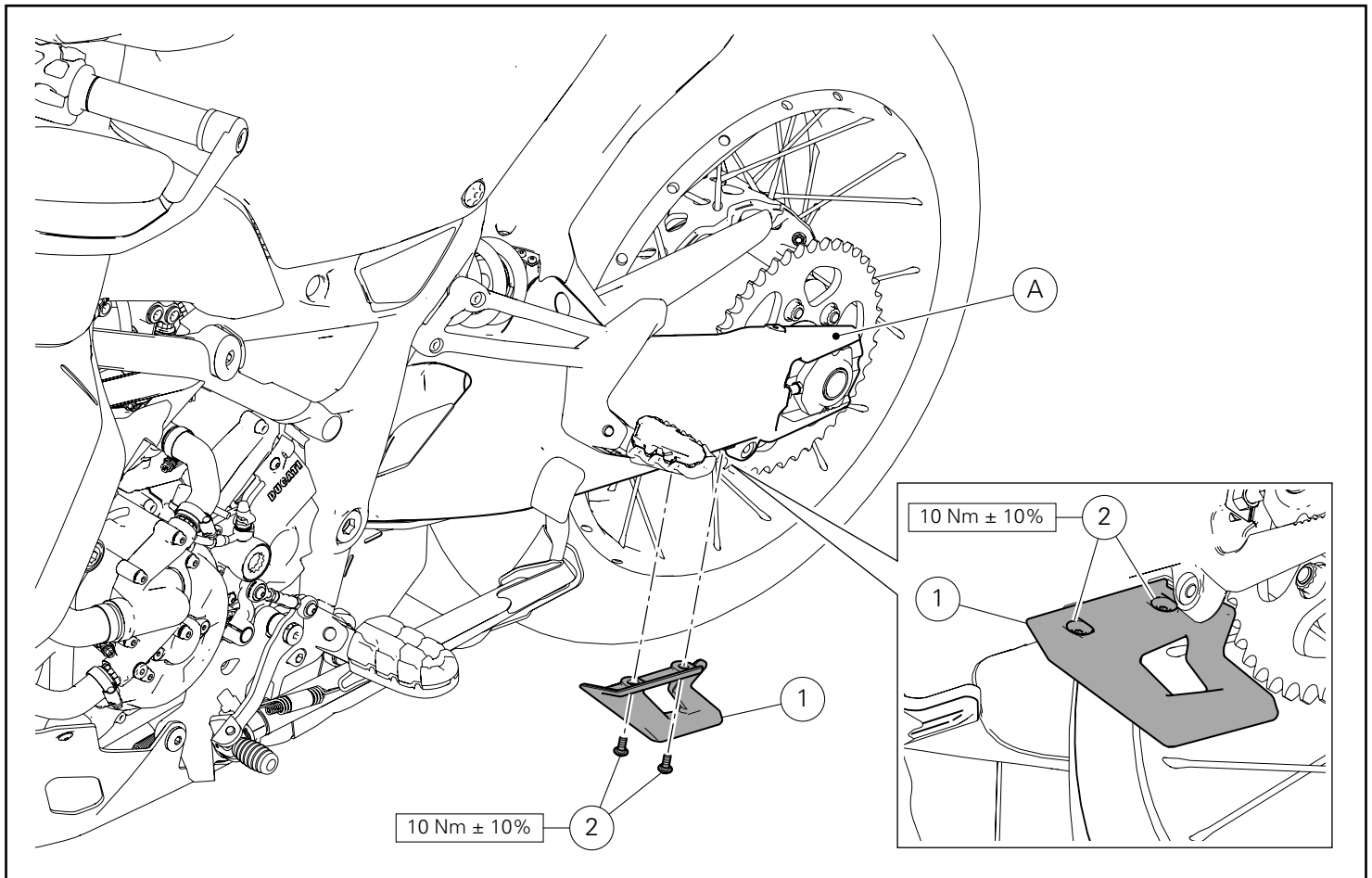

Pose composants kit

● Important

Vérifier, avant la pose, que tous les composants sont propres et en parfait état.

Adopter toutes les précautions nécessaires pour éviter d'endommager la surface externe des composants où on opère.

Pose protection chaîne inférieure sur bras oscillant avec trous M6

En intervenant du côté gauche du motorcycle positionner la protection (1) sur le bras oscillant (A) et présenter du bas les 2 vis (2).

Serrer les 2 vis (2) au couple prescrit.

Montage der Komponenten des Kits

● Wichtig

Vor der Montage überprüfen, dass sich alle Komponenten im sauberen und perfekten Zustand befinden.

Alle erforderlichen Vorsichtsmaßnahmen treffen, um eine Beschädigung der Oberflächen der Komponenten, die vom Eingriff betroffen sind, zu vermeiden.

Montage des unteren Kettenschutzes an der Hinterradschwinge mit Bohrungen M6

An der linken Seite des Motorrads arbeitend, den Schutz (1) an der Hinterradschwinge (A) anordnen, dann die 2 Schrauben (2) von unten her ansetzen.

Die 2 Schrauben (2) mit dem angegebenen Anzugsmoment anziehen.

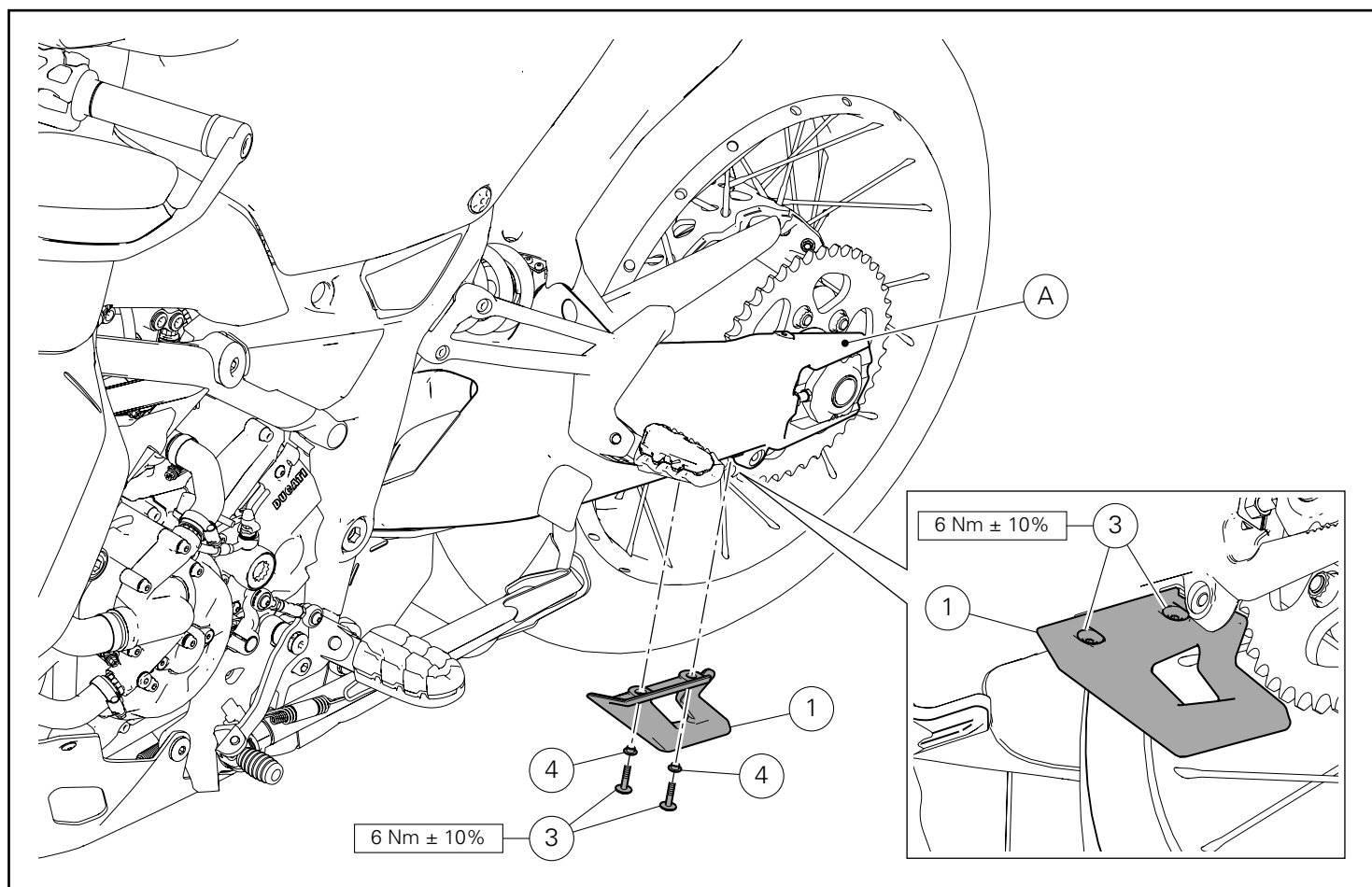

Pose protection chaîne inférieure sur bras oscillant avec trous M5

Pré-monter les 2 entretoises à collerette (4) sur les 2 vis (3).
En intervenant du côté gauche du motorcycle positionner la protection (1) sur le bras oscillant (A) et présenter du bas les 2 vis (3).
Serrer les 2 vis (3) au couple prescrit.

Montage des unteren Kettenschutzes an der Hinterradschwinge mit Bohrungen M5

Die 2 Distanzstücke mit Bund (4) an den 2 Schrauben (3) vormontieren.
An der linken Seite des Motorrads arbeitend, den Schutz (1) an der Hinterradschwinge (A) anordnen, dann die 2 Schrauben (3) von unten her ansetzen.
Die 2 Schrauben (3) mit dem angegebenen Anzugsmoment anziehen.

Conjunto de proteção para corrente inferior Lower chain protection kit



Símbolos

Para uma leitura rápida e racional, foram utilizados símbolos que evidenciam situações de máxima atenção, conselhos práticos ou simples informações. Preste muita atenção ao significado dos símbolos, pois a sua função é a de evitar a repetição de conceitos técnicos ou de avisos de segurança. Portanto, os símbolos devem ser considerados como verdadeiros "lembretes". Consulte esta página sempre que tiver dúvidas acerca do seu significado.



Atenção

O não cumprimento das instruções mostradas pode criar uma situação de perigo e causar graves lesões pessoais e até mesmo a morte.



Importante

Indica a possibilidade de causar danos ao veículo e/ou aos seus componentes se as instruções mostradas não forem executadas.



Notas

Fornecer informações úteis sobre a operação em curso.

Referências

Os detalhes evidenciados em cinza e com referência numérica (Ex. ①) representam o acessório a ser instalado e os eventuais componentes de montagem fornecidos como kit.

Os detalhes com referência alfabética (Ex. Ⓐ) representam os componentes originais presentes na moto.

Todas as indicações direita ou esquerda, referem-se ao sentido de marcha da moto.

Advertências gerais



Atenção

As operações mostradas nas páginas a seguir, se não forem executadas com boa técnica, podem prejudicar a segurança do condutor.



Atenção

As operações mostradas nas páginas a seguir, se não forem executadas com boa técnica, podem prejudicar a segurança do condutor.



Notas

Documentação necessária para executar a montagem do Conjunto: MANUAL DE OFICINA, relativo ao modelo de moto em sua posse.



Notas

Caso seja necessária a substituição de um componente do conjunto, consulte o quadro de peças de reposição em anexo.

Symbols

To allow quick and easy consultation, this manual uses graphic symbols to highlight situations in which maximum care is required, as well as practical advice or information.

Pay attention to the meaning of the symbols since they serve to avoid repeating technical concepts or safety warnings throughout the text. The symbols should therefore be seen as real reminders. Please refer to this page whenever in doubt as to their meaning.



Warning

Failure to follow these instructions might give rise to a dangerous situation and provoke severe personal injuries or even death.



Caution

Failure to follow these instructions might cause damages to the vehicle and/or its components.



Notes

Useful information on the procedure being described.

References

Parts highlighted in grey and with a numeric reference (Example ①) are the accessory to be installed and any assembly components supplied with the kit.

Parts with an alphabetic reference (Example Ⓐ) are the original components fitted on the vehicle.

Any right- or left-hand indication refers to the vehicle direction of travel.

General notes



Warning

Carefully perform the operations on the following pages since they might negatively affect rider safety.



Warning

Carefully perform the operations on the following pages since they might negatively affect rider safety.



Notes

The following documents are necessary for assembling the Kit: WORKSHOP MANUAL of your bike model.



Notes

Should it be necessary to change any kit parts, please refer to the attached spare part table.

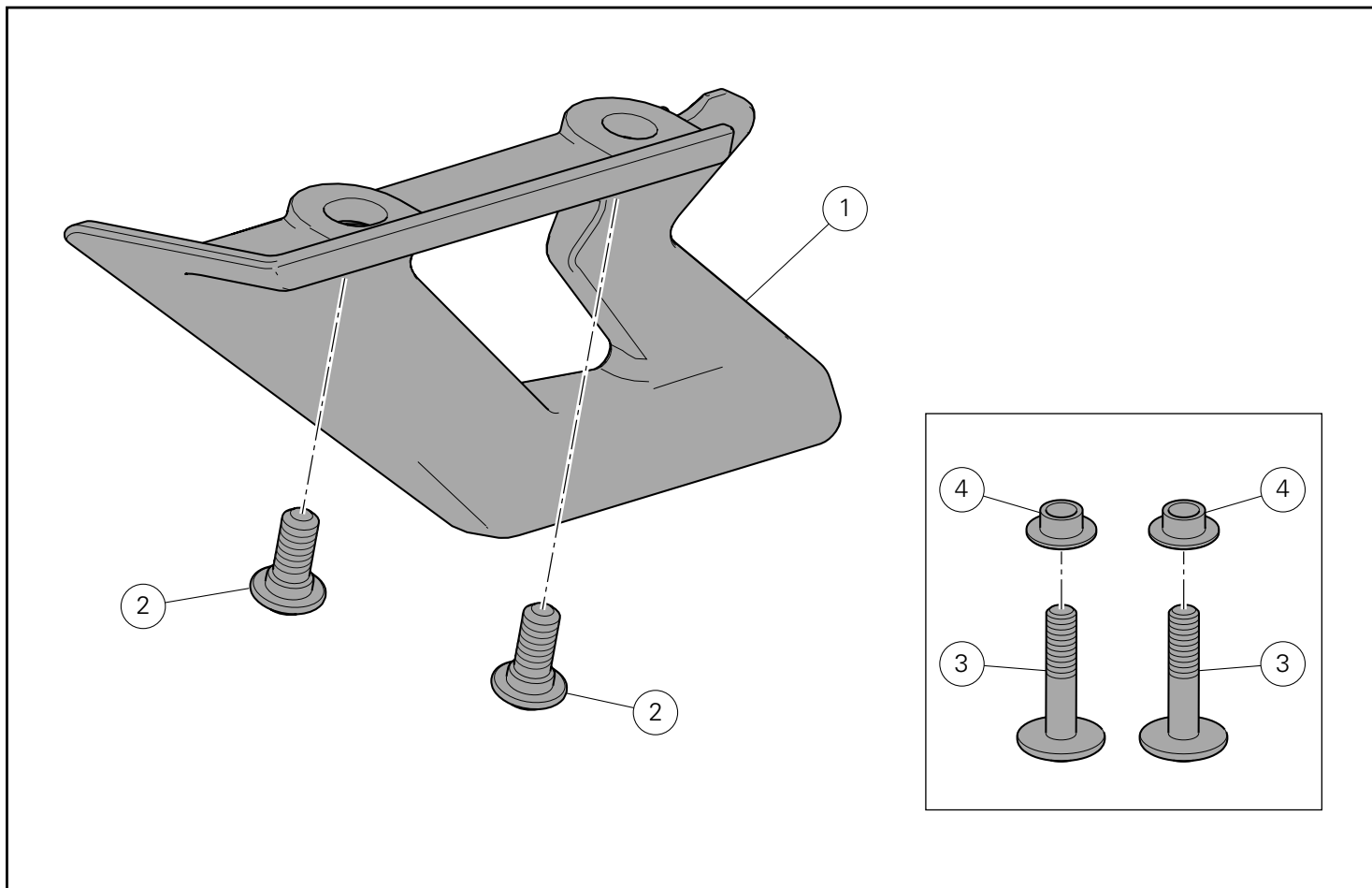

Pos.	Descrição	Description
1	Protetor de corrente inferior	Lower chain guard
2	Parafuso de cabeça abaulada com sextavado interno M6x16	TBEI screw M6x16
3	Parafuso espec. Parafuso de cabeça cilíndrica com sextavado interno M5x22	Spec. screw TCEI M5x22
4	Espaçador com colar	Spacer with collar

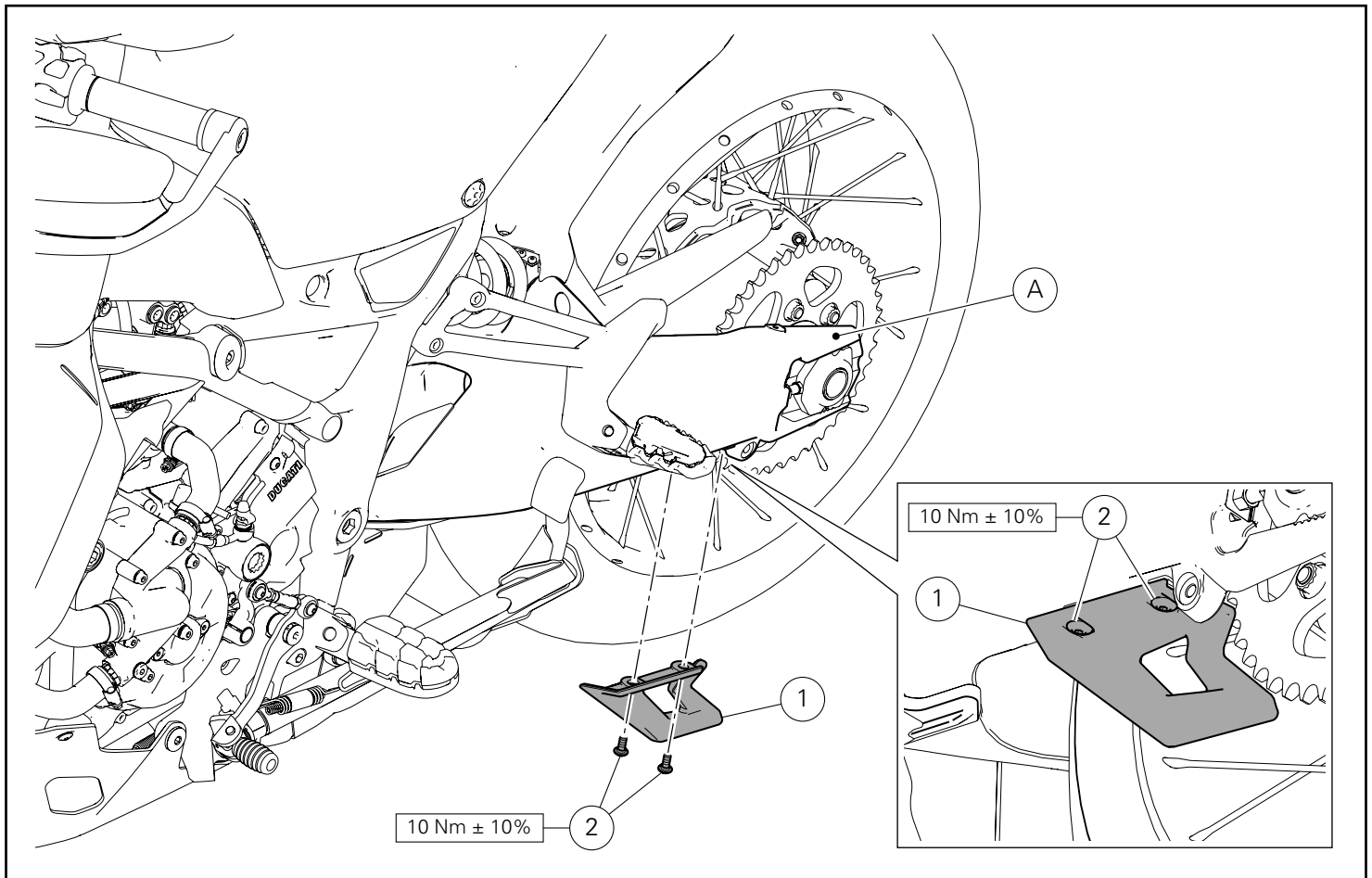

Montagem dos componentes



Importante

Verifique, antes da montagem, se todos os componentes estão limpos e em perfeito estado.

Adote todas as precauções necessárias para evitar danificar qualquer peça com a qual deve trabalhar.

Montagem da proteção para corrente inferior no braço oscilante com furos M6

Atuando no lado esquerdo da moto, posicione a proteção (1) no braço oscilante (A) e encoste por baixo os 2 parafusos (2). Aperte os 2 parafusos (2) ao binário indicado.

Kit installation



Caution

Check that all components are clean and in perfect condition before installation.

Adopt any precaution necessary to avoid damages to any part of the motorcycle you are working on.

Lower chain protection assembly on swinging arm with M6 holes

Working on the left side of the motorcycle, fit the protection (1) on the swinging arm (A) and start no.2 screws from the bottom (2). Tighten the no. 2 screws (2) to the specified torque.

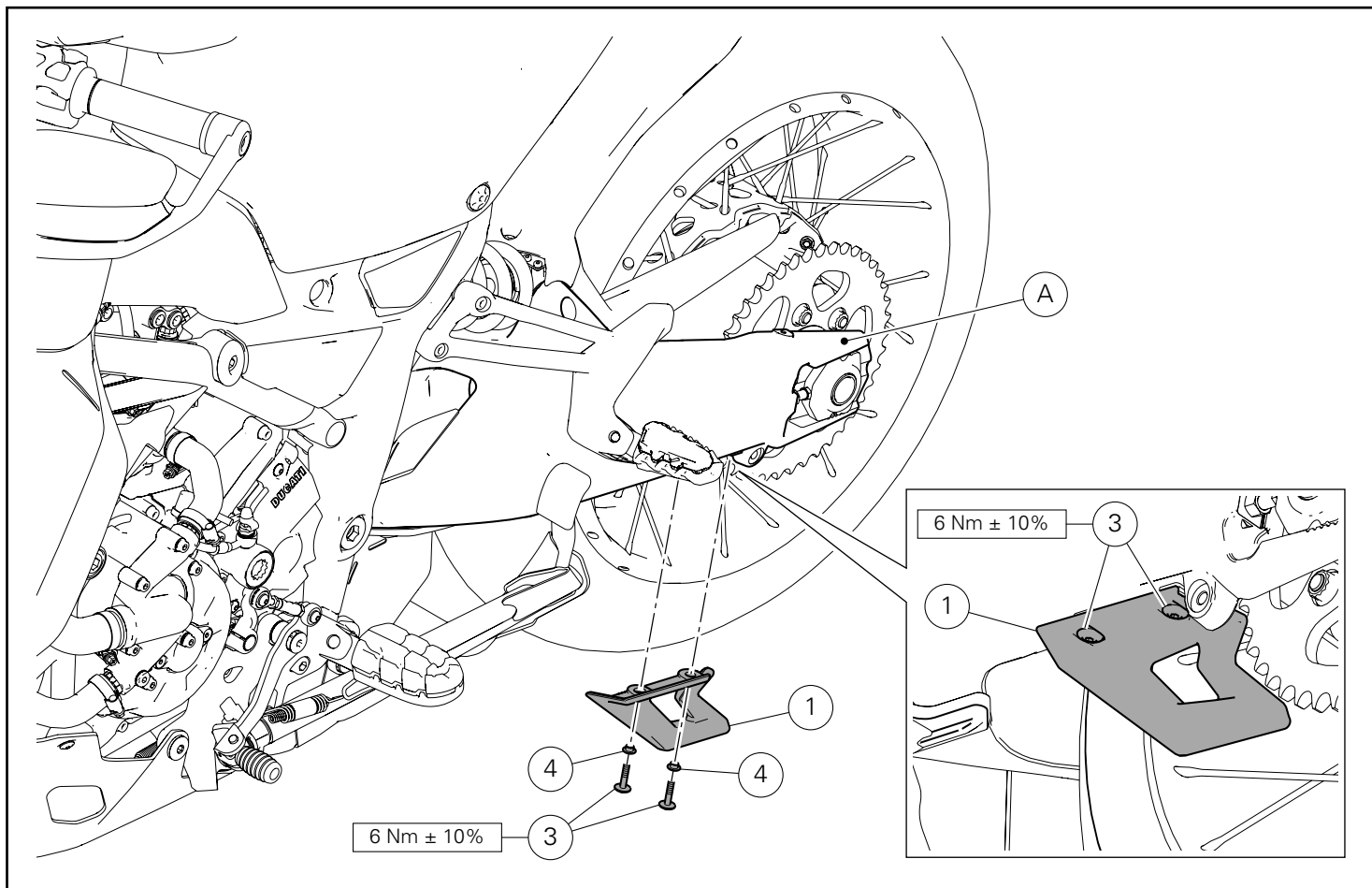

Montagem da proteção para corrente inferior no braço oscilante com furos M5

Pré-monte os 2 espaçadores com colar (4) nos 2 parafusos (3). Atuando no lado esquerdo da moto, posicione a proteção (1) no braço oscilante (A) e encoste por baixo os 2 parafusos (3). Aperte os 2 parafusos (3) ao binário indicado.

Lower chain protection assembly on swinging arm with M5 holes

Pre-assemble no. 2 spacers with collar (4) on no. 2 screws (3). Working on the left side of the motorcycle, fit the protection (1) on the swinging arm (A) and start no.2 screws from the bottom (3). Tighten the no. 2 screws (3) to the specified torque.

Kit protección cadena inferior ロアチェーンプロテクションキット



Símbolos

Para una lectura rápida y racional se han empleado símbolos que evidencian situaciones de máxima atención, consejos prácticos o simples informaciones. Prestar mucha atención al significado de los símbolos porque su función consiste en omitir la repetición de conceptos técnicos o advertencias de seguridad. Los símbolos deben considerarse como verdaderos "apuntes". Consultar esta página cada vez que se tengan dudas sobre su significado.



Atención

El incumplimiento de las instrucciones indicadas puede crear una situación de peligro y ocasionar graves lesiones e incluso la muerte.



Importante

Indica la posibilidad de provocar un daño al vehículo y/o a sus componentes si no se siguen las instrucciones indicadas.



Notas

Suministra útiles informaciones sobre la operación en curso.

Referencias

Las partes resaltadas en gris y la referencia numérica (Por ej. ①) representan el accesorio que se debe instalar y los eventuales componentes de montaje suministrados en el kit.

Las partes con referencia alfabética (Por ej. (A)) representan los componentes originales presentes en la motocicleta.

Todas las indicaciones derecha o izquierda se refieren al sentido de marcha de la motocicleta.

Advertencias generales



Atención

Las operaciones descritas en las siguientes páginas deben realizarse correctamente para no perjudicar la seguridad del piloto.



Atención

Las operaciones descritas en las siguientes páginas deben realizarse correctamente para no perjudicar la seguridad del piloto.



Notas

La documentación necesaria para realizar el montaje del Kit es el: MANUAL DE TALLER, relativo al modelo de moto en vuestro poder.



Notas

Si fuera necesario sustituir un componente del kit, consultar la tabla de recambios adjunta.

シンボル

素早くかつ合理的に読み進めることができるように、本マニュアルではいくつかのシンボルを導入し、最大限の注意を払う必要がある状況や、推奨事項、または一般情報を明確にしています。技術的概念や安全に関する警告を繰り返し記載する必要がないように機能しているため、各シンボルの意味に十分注意してください。シンボルは、実際上の“覚え書き”であると考えてください。シンボルなどの意味がわからなくなったり疑問に思う場合は、必ずこのページで調べるようにしてください。



注記

この説明書に従わずに使用すると危険な状況を招き、重大なけが、あるいは死をももたらす原因となることがあります。



重要

この説明書に従わずに使用すると、車体及び/ 又はその部品に損害を招く可能性があります



参考

操作中の内容に関する有用な情報を掲載しています。

参照

灰色で表示する部品、および参照番号 (Es. ①) で表示する部品は、キットに付属する取り付け部品および組み立て部品を示します。

参照アルファベット (Es. (A)) で表示する部品は、車両に付属するオリジナル部品を示します。

すべての右及び左の指示は車体の進行方向を向いたものです。

一般警告事項



注記

以下のページに記載されている作業が規定通りに実施されない場合、ライダーの安全性を脅かすおそれがあります。



注記

以下のページに記載されている作業が規定通りに実施されない場合、ライダーの安全性を脅かすおそれがあります。



参考

キットの取り付けに必要な資料：お手持ちの車両モデルに対応するワークショップマニュアル。



参考

キットの部品を交換する必要がある場合は、添付のスペアパーツ表を参照してください。

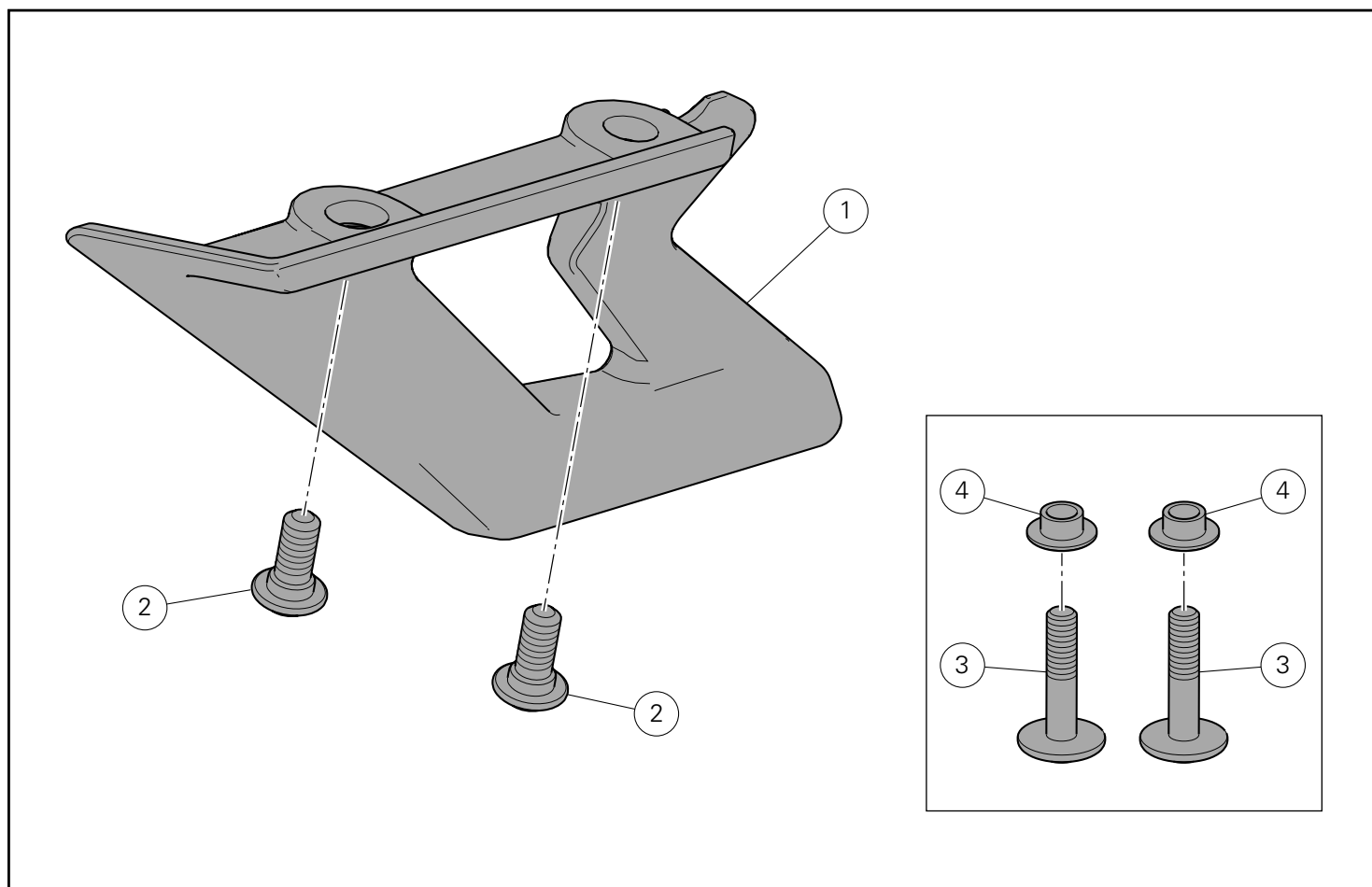

Pos.	Descripción	説明
1	Protector de cadena inferior	ロアチェーンガード
2	Tornillo TBEI M6x16	スクリュー TBEI M6X16
3	Tornillo espec. TCEI M5x22	専用スクリュー TCEI M5x22
4	Separador con collar	カラー付きスペーサー

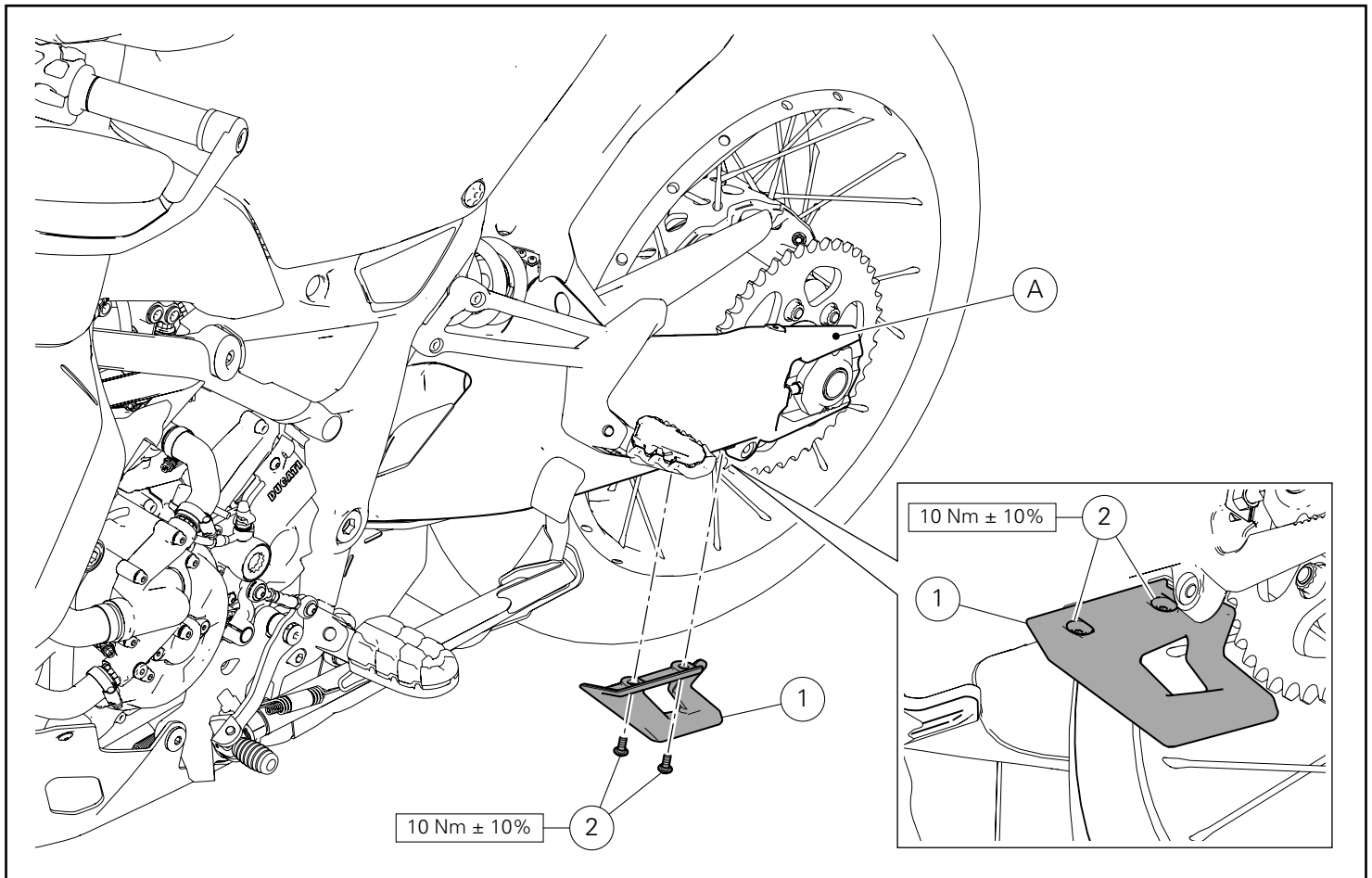

Montaje componentes kit

● Importante

Controlar, antes del montaje, que todos los componentes se encuentren limpios y en perfecto estado.
Adoptar todas las precauciones necesarias para evitar daños en la superficie exterior de los componentes donde se debe operar.

Montaje protección cadena inferior en basculante con orificios M6

Operando en el lado izquierdo de la moto, colocar la protección (1) en el basculante (A) e introducir desde abajo los 2 tornillos (2).
Ajustar los 2 tornillos (2) al par de apriete indicado.

キット部品の取り付け

● 重要

取り付け前にすべての部品に汚れがなく、完璧な状態であることを確認します。作業する部品の外側表面を傷つけないために、必要な予防措置を取ってください

スイングアーム（穴サイズ M6）へのロアチェーンプロテクションの取り付け

車両の左側で作業します。プロテクション（1）をスイングアーム（A）に配置し、下から 2 本のスクリュー（2）を差し込みます。
2 本のスクリュー（2）を規定のトルクで締め付けます。

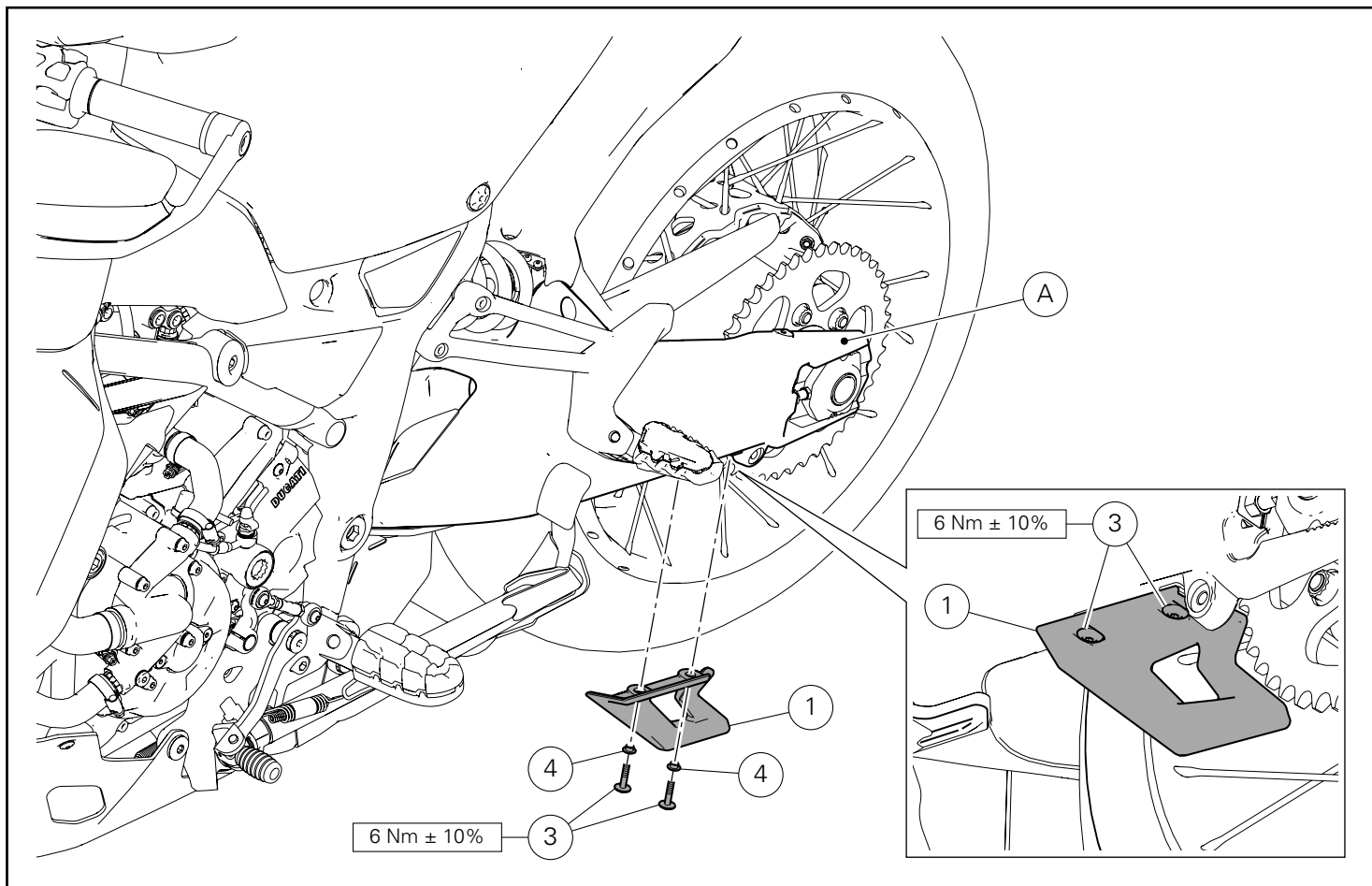

Montaje protección cadena inferior en basculante con orificios M5

Pre-montar los 2 separadores con collar (4) en los 2 tornillos (3). Operando en el lado izquierdo de la moto, colocar la protección (1) en el basculante (A) e introducir desde abajo los 2 tornillos (3). Ajustar los 2 tornillos (3) al par de apriete indicado.

スイングアーム（穴サイズ M5）へのロアチェーンプロテクションの取り付け

2 個のカラー付きスペーサー (4) を 2 本のスクリュー (3) に仮取り付けします。車両の左側で作業します。プロテクション (1) をスイングアーム (A) に配置し、下から 2 本のスクリュー (3) を差し込みます。2 本のスクリュー (3) を規定のトルクで締め付けます。



DUCATI PERFORMANCE accessories

レース専用部品 ご注文書

ご注文商品

1 P/N

商品名

2 P/N

商品名

3 P/N

商品名

4 P/N

商品名

5 P/N

商品名

お客様ご記入欄

私は上記レース専用部品を下記車両に装着し、サーキット走行のみに利用し、一般公道には利用しません。

車台番号 ZDM

モデル名

お客様署名

ご注文日

ドゥカティ正規ネットワーク店記入欄

お客様に上記レース専用部品を販売し、レース専用部品のご利用方法を説明いたしました。

販売店署名

販売日

年

月

日

販売店様へお願い

1. 上記ご記入の上、弊社アフターセールス部までFAXしてください。FAX:03-6692-1317
2. 取り付け車両1台に1枚でご使用ください。



Kit protezione catena inferiore / Lower chain protection kit / Kit protection chaîne inférieure / Kit unterer Kettenschutz / Conjunto de proteção para corrente inferior / Kit protección cadena inferior / ロアチェーンプロテクションキット

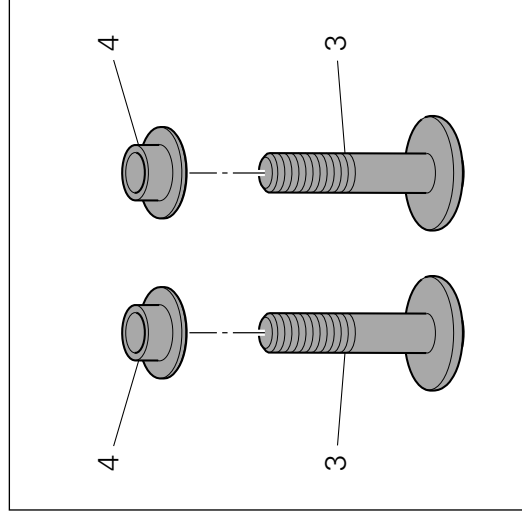
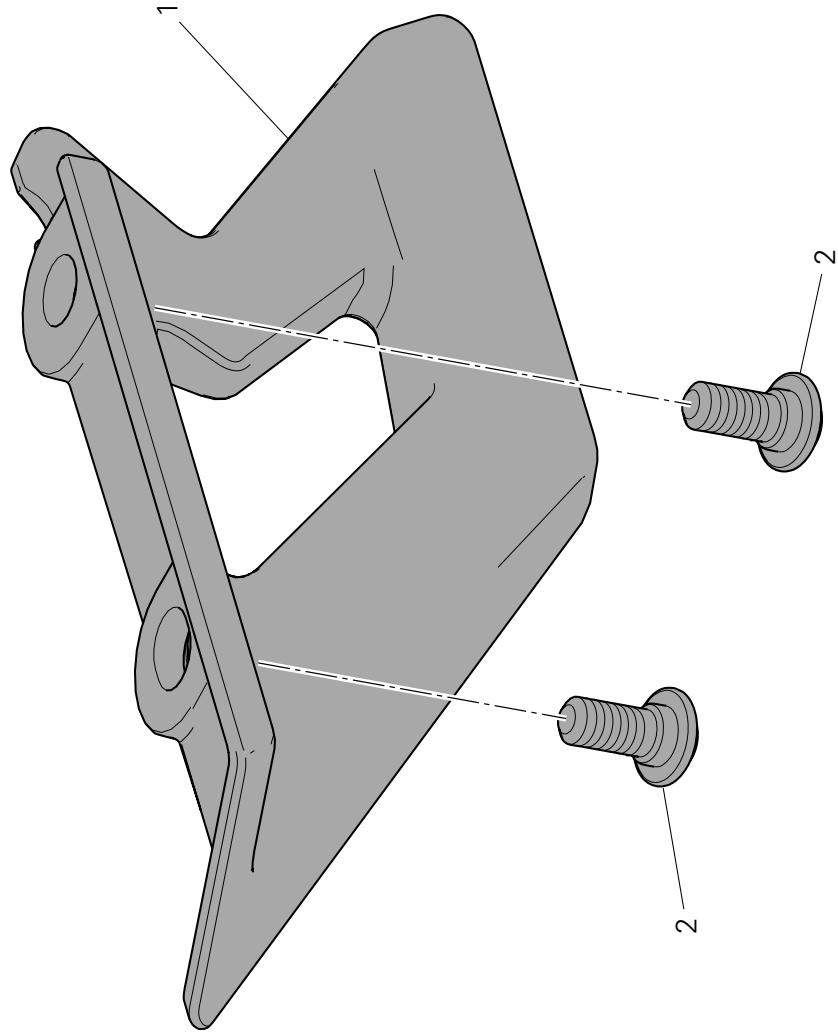

Pos.	Cod.	Denominazione	Description	Designation	Bezeichnung	Descrição	Denominacion	説明	O.ty
1	44610323A	Paracatena inferiore	Lower chain guard	Cache-chaîne inférieure	Unterer Kettenschutz	Protetor de corrente inferior	Protector de cadena inferior	ロアチェーンガード	1
2	77914391D	Vite TBEI M6x16	TBEI screw M6x16	Vis TBHC M6x16	Linieninnensechskantschraube M6x16	Parafuso de cabeça abaulada com sextavado interno M6x16	Tornillo TBEI M6x16	スクリュー TBEI M6x16	2
3	77214061AA	Vite spec. TCEI M5x22	Spec. screw TCEI M5x22	Vis spéc. TCHC M5x22	Spez.schraube mit Innensechskant M5x22	Parafuso espec. Parafuso de cabeça cilíndrica com sextavado interno M5x22	Tornillo espec. TCEI M5x22	専用スクリュー TCEI M5x22	2
4	97610441AA	Distanziale con collare	Spacer with collar	Entretoise à collerette	Distanzstück mit Bund	Espaçador com colar	Separador con collar	カラー付きスペーサー	2